

# SPIRIT

*powered by dyaco*



## 7.0T Treadmill

7.0T\_770884\_OM\_20250204

### Online Support



If you require assistance or are experiencing issues with your Spirit Machine, please contact customer care for additional help.



1-800-258-8511



[service@spiritfitness.com](mailto:service@spiritfitness.com)

### Warranty Registration



Scan to quickly and easily register your new Spirit Fitness machine.



# Table of Contents

---

<b>Product Registration</b> .....	2	Exploded View .....	49
<b>Warning / Safety Instructions</b>		Parts List.....	50
Product Labels .....	3	<b>Warranty</b> .....	53
Safety Instructions .....	4		
Electrical Safety.....	6		
Grounding Instructions .....	7		
Important Operation Instructions .....	8		
Application Specification.....	9		
Operating Principle .....	10		
Operating the 7.0T.....	11		
Parts Included .....	12		
Parts of your unit .....	13		
<b>Assembly Instructions</b> .....	14		
Setting up your Treadmill .....	19		
Console Operation .....	22		
Features .....	24		
<b>Program Operation</b> .....	26		
Data transfer software instructions .....	34		
Using a heart rate transmitter .....	37		
Machine Care .....	40		
Troubleshooting.....	46		
Specifications.....	47		

## PRODUCT REGISTRATION

---

Thank you for your recent purchase of the 7.0T. Spirit by Dyaco provides simple, reliable products that offer the most relevant feedback to caregivers and users to achieve best-in-class outcomes and empower individuals to build confidence in rebuilding and maintaining healthy lifestyles and keep in touch with their communities.

Your new product has been manufactured by one of the world's leading medical product manufactures. It is backed by one of the most comprehensive warranties in the industry. Through our dealers, distributors and manufacturer's representatives, we will do all we can to provide many years of successful and prosperous ownership. Your warranty and service needs will be addressed either through your regional sales representative or our highly trained service technicians.

It is their responsibility to provide you with both the technical knowledge and access to service personnel to make your ownership experience more informed, and resolve any issues quickly.

Serial Number	
Date of Purchase	
Dealer / Place of Purchase	

## WARRANTY REGISTRATION



Use your smartphone to scan the QR code above to quickly and easily register your new Spirit Fitness machine.

You can also go to [spiritfitness.com/warranty](https://spiritfitness.com/warranty) under the Support tab to register online.

Version: 2.1  
Revision: 02.04.25

# PRODUCT LABELS

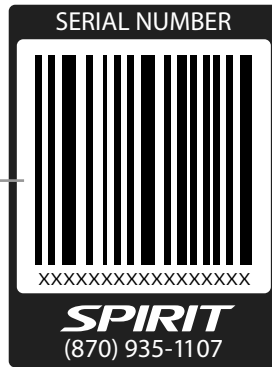

## SERIAL NUMBER STICKER

This sticker will be found on the back of the motor cover. Please record the number below the barcode for the purpose of registering your Treadmill's warranty.



## PROPOSITION 65 WARNING

This sticker will be found on the back of the motor cover. The State of California requires us to inform you that this unit was manufactured using chemicals that could cause harm with improper use.

# SAFETY INSTRUCTIONS

---

To reduce risk of injury to persons:  
Read all instructions before using this appliance.

 **WARNING** - To reduce the risk of electric shock, disconnect your 7.0T from the electrical outlet prior to cleaning and/or service work.

Read all instructions before using this appliance.

1. Do not modify this equipment without authorization of the manufacturer.
2. To reduce the risk of burns, fire, electric shock, or injury to persons, install the 7.0T on a flat level surface with access to a 120-volt AC, 60 Hz, 20-amp grounded outlet. Do not use an extension cord unless it is 12 awg(2.5mm) or larger, with only one outlet on the end. The 7.0T should be the only appliance in the electrical circuit. Do not attempt to disable the grounded plug by using improper adapters, or in any way modify the cord set; a serious shock or fire hazard may result along with computer malfunctions.
3. To avoid risk of electric shock, this equipment must only be connected to a supply main with protective earth.
4. Use this 7.0T only for it's intended use as described in this manual.
5. Keep children away from the 7.0T. There are moving parts, obvious pinch points and other caution areas that can cause harm.
6. Except as instructed for use of the 7.0T, keep hands away from all moving parts.
7. Keep the electrical cord away from heated surfaces and out of all travel lanes and do not operate the 7.0T if the cord or plug is damaged.
8. Never drop or insert any object into any openings.
9. Do not use outdoors.
10. To disconnect, turn all controls to the off position then remove the plug from the outlet.
11. This 7.0T is designed for commercial use and will meet the demands of orthopedic, sports wellness and general conditioning programs.
12. Do not attempt to use your 7.0T for any purpose other than for the purpose it is intended.
13. Over exercise may result in injury or death. If you feel faint stop exercising immediately.
14. Ensure there is a minimum space on the sides of the 7.0T of two feet for proper operation, easy access and to prevent possible injuries to others standing or walking nearby. There should be a minimum of at least one foot of free space at the front and three and a half feet at the rear.
15. Do not use any after market parts on this 7.0T, other than those recommended by Dyaco.
16. Do not attempt any servicing or adjustments other than those described in this manual. All else must be left to trained service personnel familiar with electro-mechanical equipment and authorized under the laws of the country in question to carry out maintenance and repair work.
17. Installation and assembly of this product should be performed by trained personnel only.

## SAFETY INSTRUCTIONS

---

18. Hold the handlebar for support when getting on or off the 7.0T.
19. To avoid injury please observe all minimum and maximum adjustment settings.
20. Wear proper shoes. High heels, dress shoes, sandals or bare feet are not suitable for use on the 7.0T. Quality athletic shoes are recommended to avoid leg fatigue.
21. A safety tether cord is provided with this 7.0T. It is a simple magnetic design that should be used at all times. It is for your safety should you fall or move too far back on the tread-belt. Pulling this safety tether cord will stop tread-belt movement.
- 22. User Weight Limit: 440 lbs.**



Please ensure that you review and adhere to the user weight restrictions and power requirements of your new machine. Failure to do so may result in serious injury or damage to your machine.

# ELECTRICAL SAFETY

---

## WARNING!

- Never remove any cover without first disconnecting AC power. If you suspect the voltage is low, contact your local power company or a licensed electrician for proper testing.
- Never expose this 7.0T to rain or moisture. This product is not designed for use outdoors, near a pool or spa, or in any other high humidity environment.
- The 7.0T is not protected against the ingress of water or particulate matter.
- The 7.0T is not suitable for use in an oxygen rich environment.
- If not stated otherwise Spirit by Dyaco 7.0T Treadmills are designed for operation in normal climatic surroundings (IEC 60601-1):
  - - Temperature: + 10° ... + 36° C
  - - Relative humidity: 30 ... 90 % (non condensing)
  - - Air pressure: 700 ... 1060 mbar
  - - Maximum operating altitude: approx. 10,000 feet (3000m), without pressurization
  - - Transport and store the 7.0T at a temperature of – 20° ... + 50° C.
- Motor: 3.0HP AC
- Power: 120 volts, 60 Hz, dedicated 20-amp circuit (NEMA 5-20P standard power plug/ receptacle type)

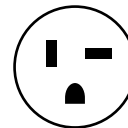

NEMA 5-20P

# GROUNDING INSTRUCTIONS

---

This product must be grounded. In the unlikely event that the 7.0T's electrical system should malfunction or breakdown grounding provides a path of the least resistance for electric current, reducing the risk of electric shock. This product is equipped with a cord having an equipment-grounding plug. The plug must be plugged into an appropriate outlet that is properly installed and grounded in accordance with all local codes and ordinances..

**DANGER** - Improper connection of the equipment-grounding conductor can result in a risk of electric shock. Check with a qualified electrician or serviceman if you are in doubt whether the product is properly grounded. Do not modify the plug provided with the product if it will not fit the outlet; have a proper outlet installed by a qualified electrician.

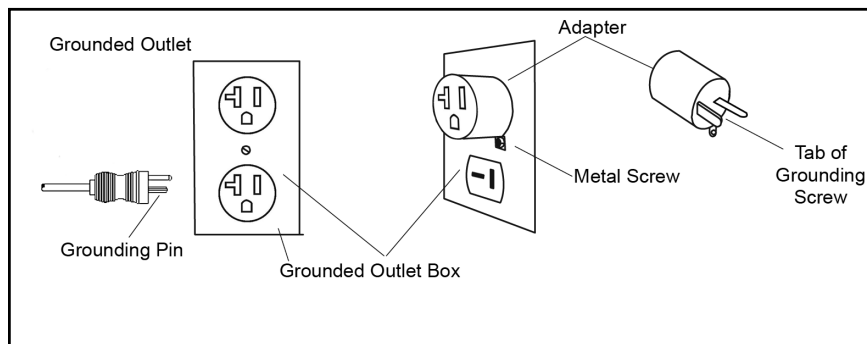

# OPERATION INSTRUCTIONS

---



## WARNING!

- Never use the 7.0T during an electrical storm. Surges may occur in your facility power supply that could damage the 7.0T's components.
- All users should have medical clearance before starting any rigorous exercise program.
- Start the user at a safe exercise level. Do not allow the user to be over exerted. Symptoms to watch for, but not limited to, are: shortness of breath or difficulty in breathing, pain or discomfort, feeling faint.
- Make sure the user warms up and cools down properly to avoid over taxing the cardio vascular system. Allow three to five minutes of warm up and cool down during each exercise session.
- 7.0T rehabilitation Treadmill should not be used for patients with severe osteoporosis, non-union fractures, debilitating dizziness, or poor safety awareness/ cognition. Do not use for patients weighing greater than 200kgs (bariatric). Do not use for patients with acute conditions such as pulmonary embolus, thrombus, acute MI, acute fractures, or BP over 180/110 Hg.
- **SAVE THESE INSTRUCTIONS - THINK SAFETY!**

# APPLICATION SPECIFICATION

---

## MEDICAL PURPOSES

- Patient warm-up before a physical therapy session.
- Have the patient walk to improve ambulation and range of motion after knee/hip/ankle surgery or neurological conditions.
- Allow patients to perform cardiovascular exercise.
- Used for open kinetic chain exercise only, patient is not restrained or connected to the 7.0T.
- 7.0T is a device intended to be used to redevelop muscles or restore motion to joints.

## INTENDED PATIENT POPULATION

- Male and Female Adults. Children at the discretion of a Qualified Physical Therapist and or parental consent.
- Maximal patient's weight is 440 lb.
- Patient must be ambulatory.
- Patient should have medical clearance before starting any rigorous exercise program. This is especially important for person with a history of heart disease or other high risk factors.

## INTENDED PART OF THE BODY OR TYPE OF TISSUE APPLIED TO OR INTERACTED WITH

- Contact site: hands, feet, and trunk
- Condition: should not have any trauma

## INTENDED CONDITIONS OF USE

- Environment including hygienic requirements
- General: intended for indoors use. This product is not designed for use outdoors, near a pool or spa, or in any other high humidity environment.
- - Conditions of visibility:
- Ambient luminance: standard ambient room lighting is sufficient.
- Viewing distance: 1 m
- Viewing angle: 120°
- - Physical
- Temperature range: 10°C ~ 36°C
- Relative humidity range: 30% R.H. ~ 90% R.H., non-condensing
- - Hygienic requirements: there is no particular restriction on hygienic requirements.
- • Frequency of use
- - Dependent on therapist's plan.
- • Location
- - Intended for hospital use, clinic use, home use and research in academic institutions.
- • Mobility
- - The product is intended to be fixed.

## **OPERATING PRINCIPLE**

---

The operator will start the 7.0T and use the speed and incline keys to control motors. When the speed key is pressed, a signal will be sent to the AC motor inverter to request a change. The inverter will then send the appropriate amount of power the AC drive motor to reach the requested speed. The motor drives the front roller (which in turn moves the walking belt) through pulleys and fan belt. The incline motor is operated when the operator presses the incline keys. A command is generated that is transmitted to the incline control board where a relay is energized sending AC power to the motor until it reaches the desired position.

- **INTENDED INSTALLER**
- There is no particular restriction on age, gender, height, weight, ability and culture.
- Education: High School or above
- Knowledge: The installer shall be able to manipulate this product properly.
- Discipline: The installer shall be given a specific training by manufacturer.
- Experience: The installer must have experience in product assembly and disassembly.
- Background: The installer must be electro-mechanically trained.
- Professional competence: Normal vision ability required.

## **OPERATING THE 7.0T**

---

The 7.0T is intended to be used in aiding in the physical rehabilitation process for patients with orthopedic and neurological problems. Also used in sports medicine, wellness and general conditioning programs.

### **TYPICAL APPLICATIONS FOR THIS TYPE OF PRODUCT ARE**

- Patient warm up before physical therapy session.
- Have the patient walk to improve ambulation and range of motion after knee/hip/ankle surgery or neurological conditions.
- Allow patients to perform cardiovascular exercise
- Used for open kinetic chain exercise only, patient is not restrained or connected to the 7.0T.

### **UNIQUE USES FOR THE 7.0T**

- The walking belt allows for both forward and reverse walking.
- The front and rear incline allows for uphill and downhill walking.
- Symmetry program measures distance between left and right step lengths. Graphical bio-feedback display motivates patients to maintain even step symmetry between left and right legs.

### **OTHER FEATURES OF THE 7.0T**

- Belt speed settings start at 0.1 km/hr.
- The parallel handrails are adjustable to accommodate for pediatric to large adult sizes.

# PARTS INCLUDED

---

Tools.

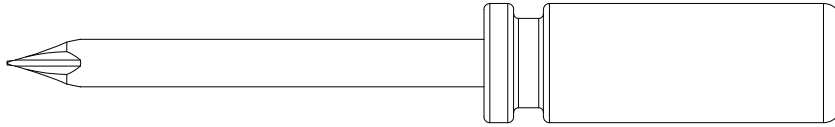

#113-Phillips screw driver(1PCS)



#137-5mm Allen wrench(1PCS)

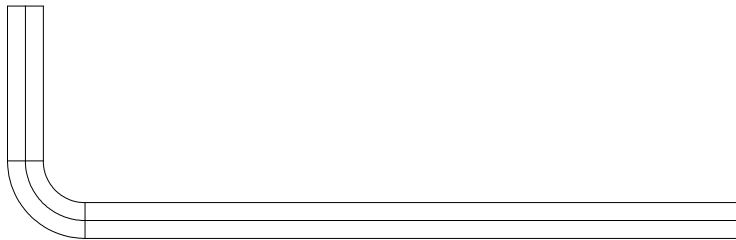

#259-6mm Allen wrench(1PCS)

STEP1

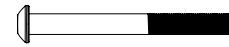

#104-3/8" x 3-3/4" (6PCS)



#58- Ø10 x 2T (6PCS)



#59-3/8" x 25 x 2T(6PCS)

STEP2



#153-3/8" x 3/4"(6PCS)



#58- Ø10 x 2T(6PCS)



#59-3/8" x 25 x 2T(6PCS)



#108-M8 x 12L (6PCS)



#73-M5 x 12L(4PCS)

STEP3



#110-M5 x 10L (2PCS)



#112-M5 x 30L(2PCS)

STEP4



#153-3/8" x 3/4" (8PCS)



#59-3/8" x 25 x 2T (8PCS)



#226-3/8" x 2"(8PCS)

## PARTS OF YOUR TREADMILL

---

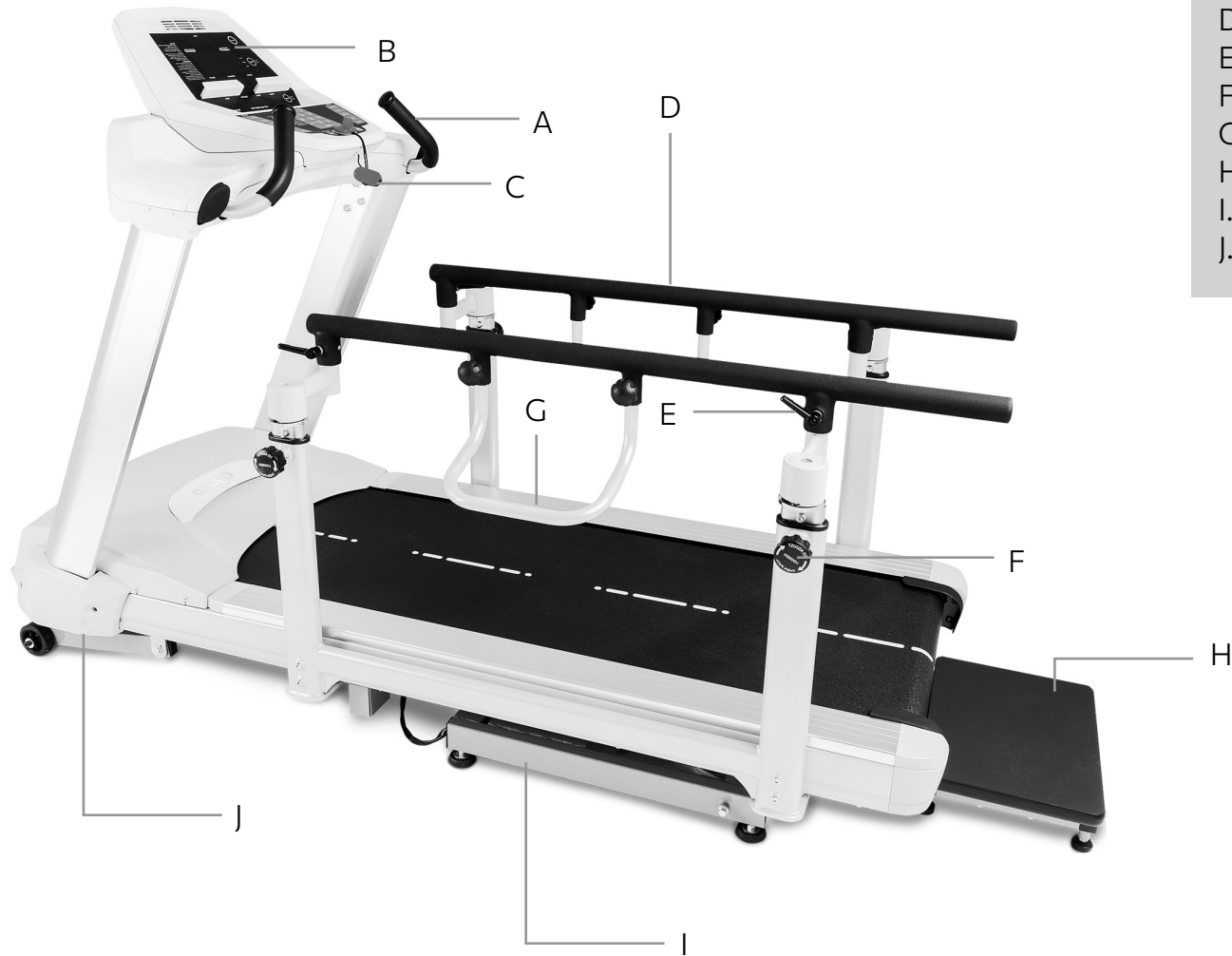

- A. Hand grips
- B. Electronic console
- C. Safety Key
- D. Adjustable handrails
- E. Handrail horizontal adjustment
- F. Handrail vertical adjustment
- G. Handrail lift bar
- H. Rear step
- I. Rear incline
- J. Front incline

## **PRE-ASSEMBLY**

---

1. Cut the straps, then lift the box over the unit and unpack.
2. Carefully remove all parts from the carton and inspect for any damage or missing parts. If parts are damaged or missing, contact your dealer immediately.
3. Locate the hardware package. Remove the tools first.
4. Remove the hardware for each step as needed to avoid confusion. The numbers in the instructions that are in parenthesis (#) are the item number from the assembly drawing for reference.

## ASSEMBLY - STEP ONE

---

1. The **right side upright tube (19)** has the computer cables pre-installed. Lift the tube off the walking surface and attach it to the base frame. You need to gently pull on the computer cables as you align the upright tube into the bracket on the base frame, taking the slack out so the cable does not get pinched between the tube and the base frame. Assemble one **3/8" x 3-3/4" bolt (104)**, **3/8" split washer (58)** and **3/8" flat washer (59)** through the top hole in the **retaining plate (21)**, and corresponding top hole in the upright tube, and screw into the base frame. Now install the other **two bolts (104)** and **washers (58 & 59)** and hand tighten all three. Do not torque the bolts yet until the upper console frame is installed.
2. Install the **left upright (18)** in the same manner.

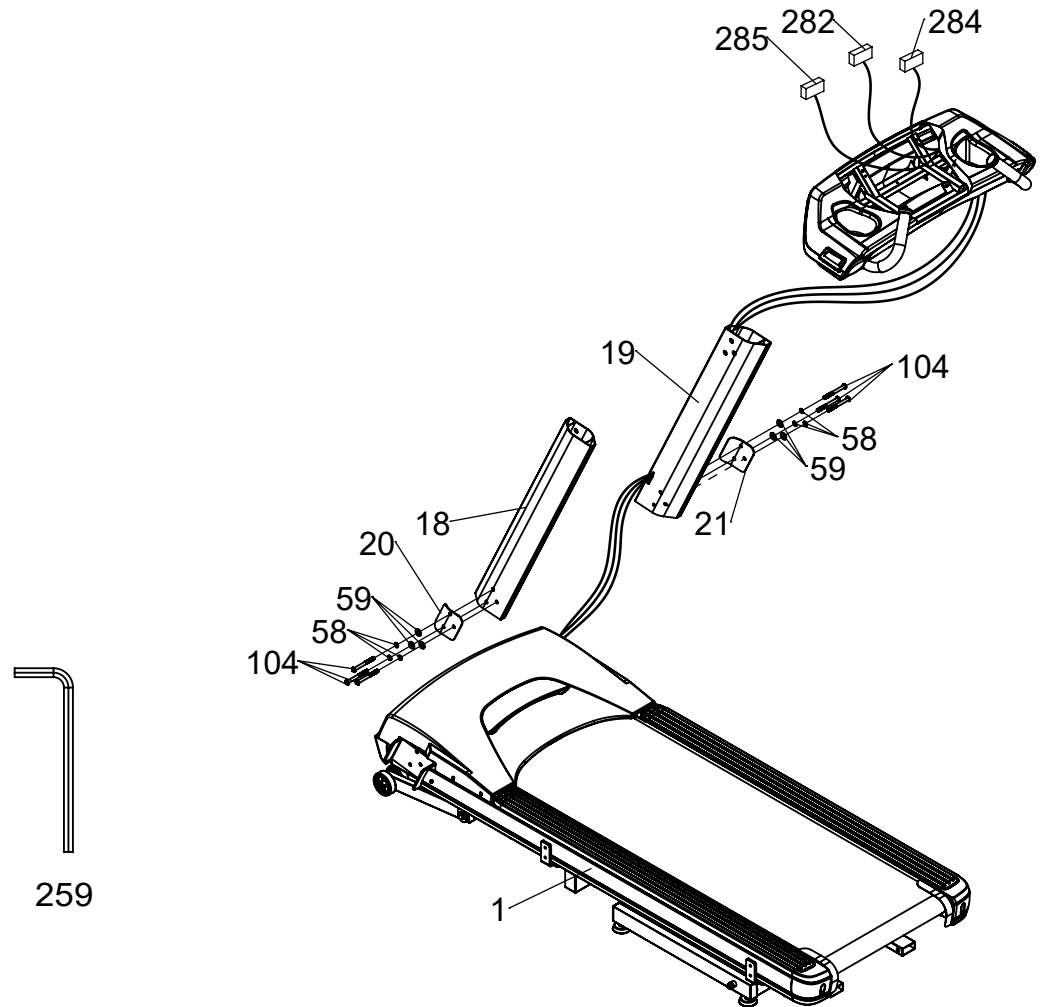

## ASSEMBLY - STEP TWO

---

1. Install the two **mounting brackets (3 & 4)** with the six **M8 x 12mm screws (108)**. Refer to the important instructions on the following page for this step.
2. Mount the **console frame (5)** to the **upright tubes (18 & 19)** with six **3/8" x 3/4" bolts (153)**, **3/8" split washers (58)** and **3/8" flat washers (59)**. Be careful not to pinch the computer cables.
3. Firmly tighten the six **bolts (104)** at the bottom of the uprights and install the two **end caps (32 & 33)** with the four **M5 x 12mm screws (73)**.

When assembling the console mounting brackets (Items 3&4,) please be sure to slide the brackets all the way towards the back of the console frame before tightening the bolts.

Push mounting bracket all the way towards the back of the console, then tighten screws.

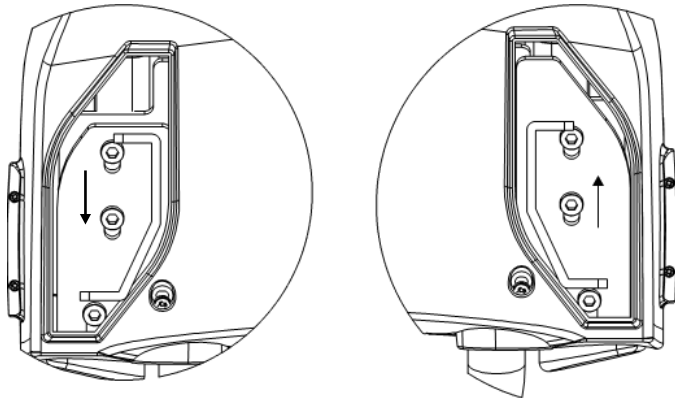

113



137



259

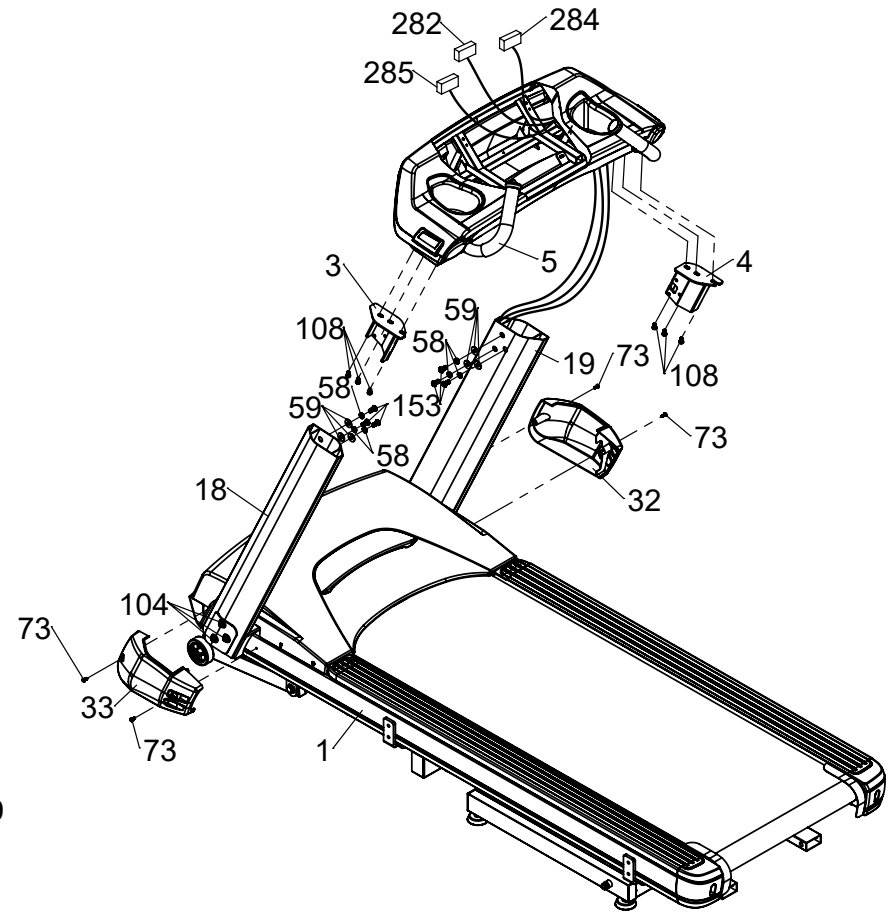

## ASSEMBLY - STEP THREE

---

1. Plug all the connectors in back of the console.
2. Mount the **console (36)** to the **console frame (5)** with two **M5 x 30mm screws (112)** in the top holes and two **M5 x 10mm screws (110)** in the bottom holes in the back side of the console frame.

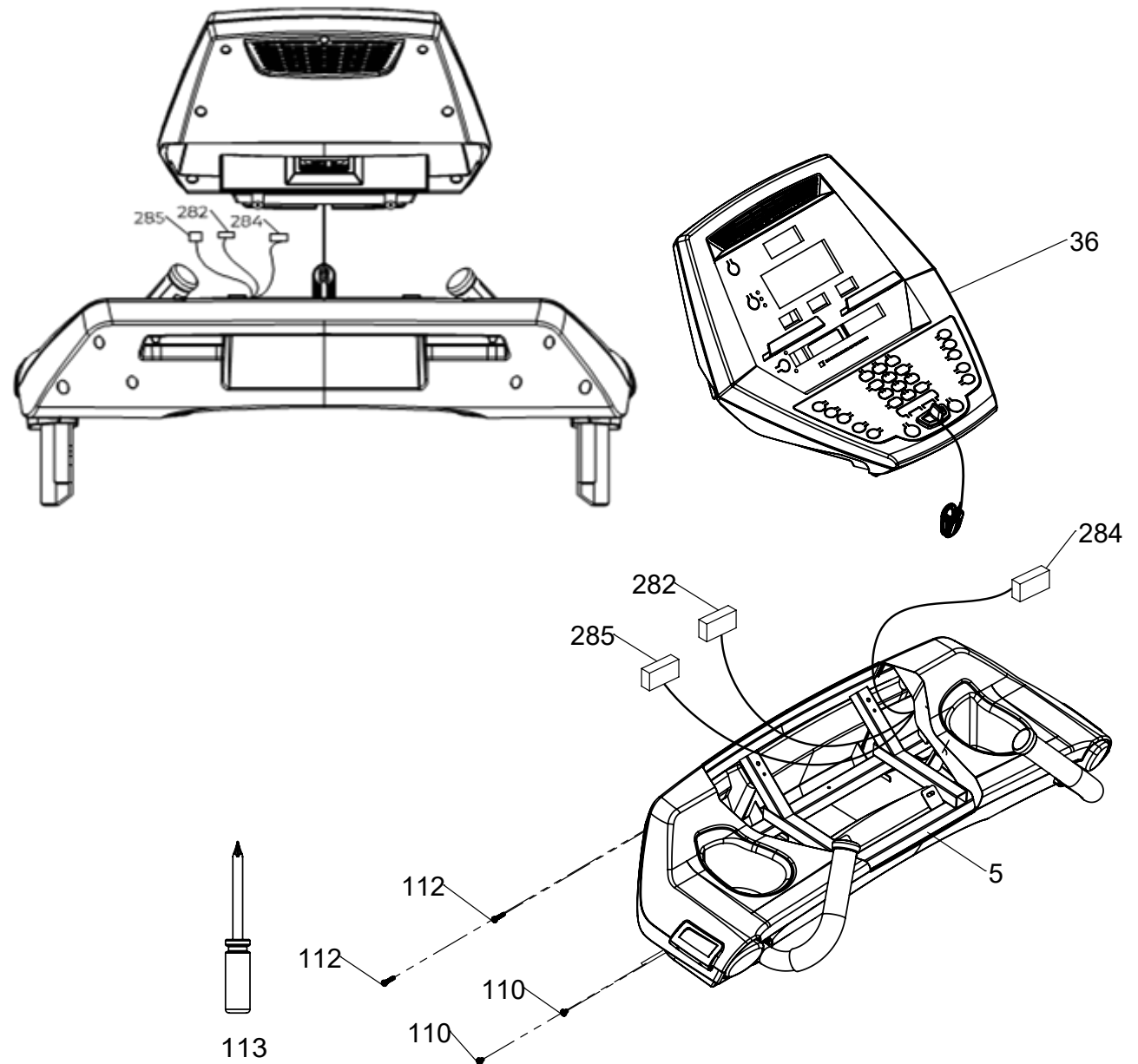

## ASSEMBLY - STEP FOUR

---

1. Install the eight **3/8" x 3/4" bolts (153)** and **3/8" flat washers (59)** into the holes on the underside of the frame. Only thread them into the holes two or three turns so the slots in the handrail brackets can slide onto the bolts easily. Slide the handrail onto the bolts and hand-tighten them. Thread the eight **3/8" x 2" bolts (226)** into the sides of the handrails. Once all the bolts are installed, tighten all of them securely.
2. Install the **Lift Bars (192)** to the parallel bars and secure with the **knobs (207)**.
3. Install the **rear step (181)** by sliding into the receiving tubes under the rear of the deck and secure with the two **pins (217)**. Raising the rear incline may make it easier to line up the holes for the pins.

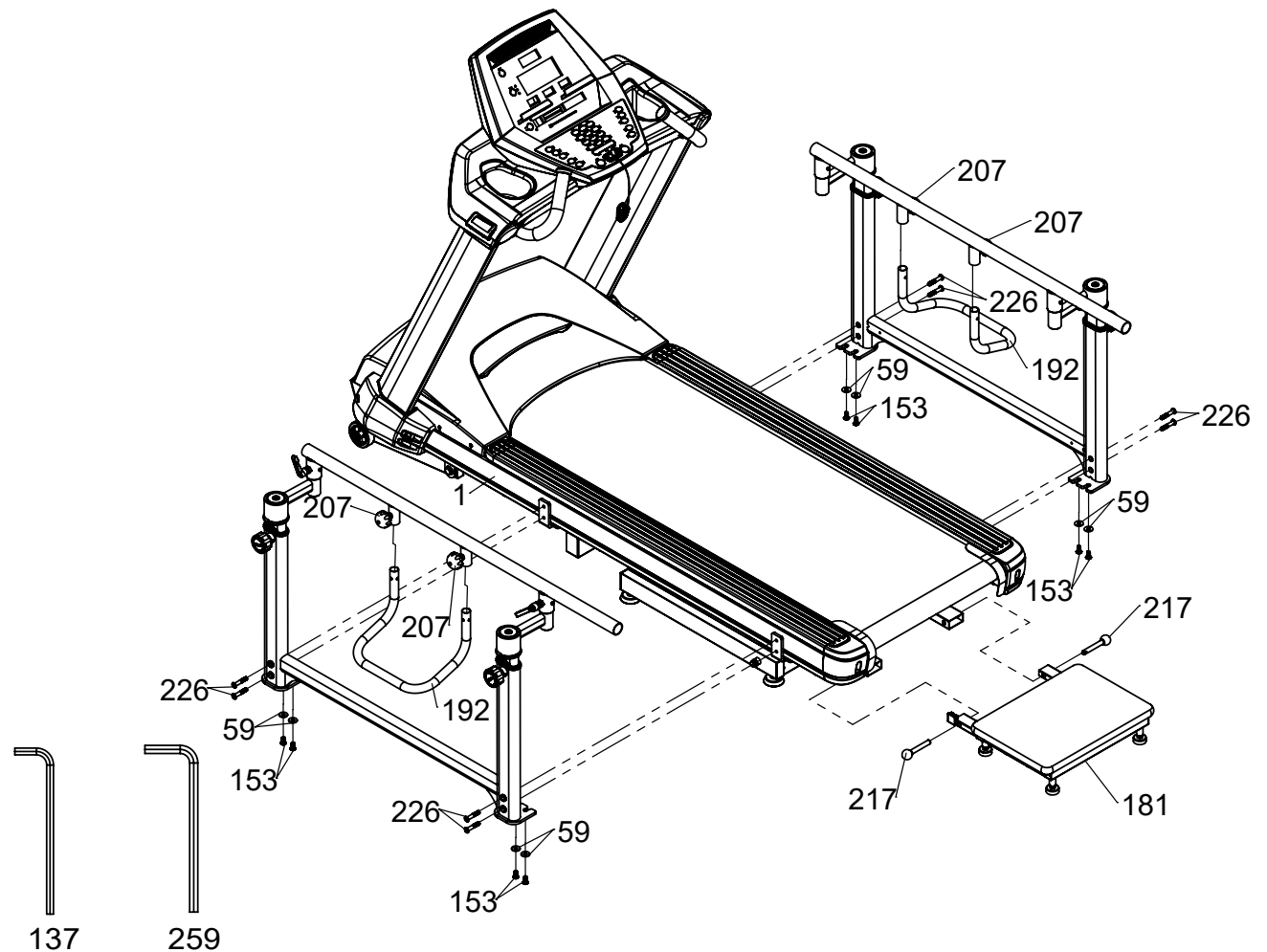

# SETTING UP YOUR TREADMILL

---

## Plugging in

The 7.0T A.C. mains input connector is located in the front of the 7.0T. The input module has an input connector for the line cord, a power switch and a 20 amp circuit breaker. Turn the power switch to off when the 7.0T is not in use.

## Leveling the 7.0T

Once the 7.0T is assembled, and placed on a flat level floor, it may be necessary to adjust the leveling glides on the bottom of the rear incline unit to ensure proper stability of the 7.0T. Use a 1/2" wrench to loosen the top nut of the leveler. Adjust the levelers by hand as necessary to remove any wobble in the unit. Then tighten the top nut against the bottom of the stabilizer tube. Make sure the bottom nut remains cinched against the leveling foot.

## Adjusting the Vertical Handrail Position

To lift: Turn both the left and right vertical adjustment knobs counterclockwise one or two rotations. Then just grab the lift bar and pull up. The locking pins in the knobs will automatically ratchet into the indexing holes in the tubes. Tighten the knobs when desired position is set. There is a numbered scale on the tubes for repeatable settings.

To lower: Loosen the two knobs and then pull them out and rotate slightly until the knob remains out on its own. The pin should now be disengaged from the tube and you can use the lift bar to lower the rails. Lower the rail past the position you desire and rotate the knob again so the pin can engage the holes in the tube. Now lift the rails to the desired position and lock the knob.

## Handlebar Adjustments

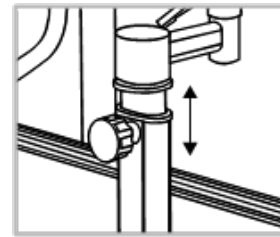

Vertical Adjustment

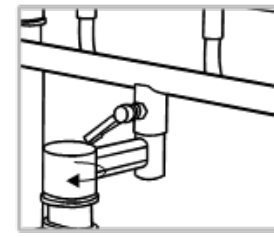

Horizontal Adjustment

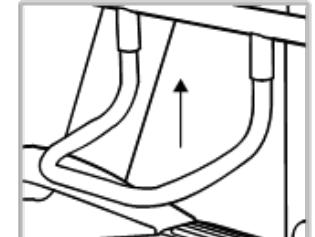

Lift Bar

## Lift Bar

The lift bar will make raising and lowering the handrails easier. You can remove the lift bars for better patient access by loosening the locking knobs. Hold the bar with one hand and loosen the knobs with the other so the lift bar does not suddenly fall to the floor.

## Rear Step

Additional step lowers the step-up height to 4 inches. To install or remove the step easily there are two removable pins located under the rear of the 7.0T. Be sure these two pins are in place before using.

## Adjusting the Horizontal Handrail Position

Turn both the left and right levers counterclockwise one rotation. Move the rails to the desired position and re-lock the levers. There are numbered scales on the tubes for repeatable settings. The levers may be blocked by the rotating tube when position is changed. The levers can be repositioned by pulling out and rotating them to a new position allowing tightening.

## QUICK START

---

1. This is the quickest way to start an exercise session. After the console powers up you just press the Start key to begin; this will initiate the Quick Start mode. In Quick Start the speed will be set to zero until the user adjusts the speed. Time will count up from zero, all workout data will start to accrue and the speed and incline may be adjusted manually by pressing the Up or Down key. The dot matrix will display a speed level. As you increase the speed, more rows will light indicating a harder workout.
2. The dot matrix has 24 columns of lights and each column represents 1 minute in the Quick start program (time per column can be modified in other programs). At the end of the 24th column (or 24 minutes of work) the display will wrap around and restart at the first column again.

# CONSOLE SCREEN - OVERVIEW



## POWER ON & CONSOLE OPERATION

---

When initially powered on the console will perform an internal self-test. During this time all the lights will turn on for a short time. The message window will display a software version (i.e. VER 1.0) and the distance window will display an odometer reading indicating how many virtual miles (or Kilometers) the 7.0T has gone.

The time window displays how many hours the 7.0T has been used.

The odometer will remain displayed for only a few seconds then the console will go to the start up display, also known as Idle Mode. The message window will be scrolling the start up message. You may now begin to use the 7.0T.

The console will automatically power down after 30 minutes of inactivity. Press any key to wake the console up again. To disable this function so console always remains powered on see Maintenance section on page 74. Always turn off the main power switch when the 7.0T is not in use.

## Set up

The set up key function will allow you to enter patient data and customize the settings of the 7.0T. When the set up key is pressed the first option in the menu appears. Use the up/down arrows to scroll through the menu and press the enter key to select an option.

## Set up menu

- **Patient data**
- Age : used in Vo2 and heart rate programs.
- Gender : used in Vo2 program.
- Weight : used in METs and Calorie calculations and Vo2 program.
- Height : used in the Symmetry program.

## BASIC INFORMATION

---

The dot matrix display is used for displaying graphic feedback and has three basic displays for most programs. When you begin a program, the dot matrix will display a speed profile. To the left of the dot matrix there is a key labeled display. Pressing this key will switch the display to show an incline grade and then a track. When the LEDs are blinking, the graph will scan through the three displays.

The four data windows display:

- Time: Program time remaining, or elapsed time in quick start mode.
- Incline grade: Front incline range 0 to 15 %. Rear incline range 0 to minus 10%
- Distance: Displayed in miles or kilometers, selected in Maintenance mode.
- Speed: Displayed in mph or kph. Range from minus 3 mph (5 kph) to plus 10 mph (16 kph) in 0.1 increments. True zero speed provided by a mechanical brake when ever motor is idle.

The message window is the main display for programming instructions and relevant measurements during a program. The measurement data shown varies depending on the program.

Measurements include:

- Pulse: Heart rate displayed in beats per minute, from 0 to 240 bpm.
- METs: Metabolic equivalent; values of activities range from 0.9 (sleeping) to 23 (running at 22.5 km/h).
- Calories: Or kilocalorie (kcal), nutritional Calories burned during exercise.
- Pace: Displayed as minutes per mile (or kilometer).
- Step cadence: Steps per minute average.
- Step length: Heel strike to heel strike step length in inches or centimeters.
- Symmetry: The percentage of difference between the left and right step length.

To the left of the message window is a display key that allows you to switch the data shown.

Below the message window is a heart icon and a bar graph. Wearing an optional heart rate chest belt transmitter will start the Heart Icon blinking (this may take a few seconds). The message window will display your heart rate in beats per minute. The bar graph represents the percentage of maximum heart rate.

Note: Enter the correct age in set up for the bar graph to be accurate. Refer to heart rate section for details about these features.

Function keys

The stop/reset key provides several functions:

- Pressing the stop/reset key once during a program will pause the program. To resume the exercise session just press the start key.
- If the stop/reset button is pressed twice during a workout ends the program and a summary of information for the exercise session will be displayed.
- If the stop/reset key is held down for 3 seconds the console will perform a complete reset.
- During data entry for a program the stop/reset key performs a previous screen function. This allows you to go back one step in the programming each time you press the stop/reset key.

The program keys may be used to preview each program when in the idle mode. Press each program key to preview the program profile. To begin a program press the corresponding program key and then press the enter key to select the program.

The program keys also function as a number key pad when you are in the data-setup mode. The number for each key is shown below the program name. If you are entering new data such as time, age, weight etc., you can use these keys to enter the numbers quickly.

## FEATURES

---

### Forward

This key sets the belt direction to forward. Forward is the default direction setting when the 7.0T is powered on and any time the console is in the idle mode. If the belt is already set in the reverse direction, it will change the direction of the belt to forward. If the belt is moving in reverse when the key is pressed the belt will slow down to zero speed and then speed changes in the forward direction are allowed.

### Reverse

This key sets the belt direction to reverse if the belt is already set to forward direction. This function only operates in quick start or manual mode. If the belt is moving when the key is pressed the belt will slow down to zero speed then allow speed changes in the reverse direction. The speed window will show a minus (-) sign indicating the speed is set to reverse.

### Acceleration - Deceleration

This function adjusts the acceleration and deceleration rate of the walking belt by allowing you to change the amount of time it takes for the belt to change speeds. The adjustment value is in seconds. You can input how many seconds it takes for the belt to change 1 mph of speed. The default setting is 3 seconds, which means the belt will take 3 seconds to go from zero to 1 mph. The range can be set from 1 second to 60 seconds. This function can be disabled in the Maintenance mode.

### Incline

Press this key to return to front incline function if decline function is active.

### Decline

Allows operation of the rear deck motor for decline function. This key only operates in quick start or manual modes. When the function is active the grade window will show a minus (-) sign indicating the grade is set for decline.

### Zero Percent

Returns the deck to zero percent when pressed.

### Deck Lift Program

The deck-lift program is also used with the basic un-weighting system. Raise the deck and connect the patients un-weighting harness to the un-weighting system. The up and down keys can be used to raise or lower the deck for un-weighting the patient.

## FEATURES

---

### Deck-lift program

This program allows you to raise the entire deck parallel to the floor. In this mode the deck, rear step and handrails can be used for step-up, step-down, stretching and PNF/PTA exercises. Lifting the deck while a patient walks allows the therapist to assist the patient by moving their legs without having to bend over too far.

- Instructions for raising and lowering the deck. Press the deck-lift key to activate the program.



- The grade window will display 01 which indicates the first level. The starting height from the step to the deck at level 1 is 5.25 inches (13.34cm). The height will be displayed in the message window. The height from the floor to the step is 4 inches (10 cm).
- Press the up and down keys to raise and lower the deck. There are 30 levels available with each level raising the deck 1/4 inch (6.35mm). At level 30 the deck height is 12.5 inches (31.75cm) from the step. Note that the measurements are approximate.
- In the deck-lift program you can press the start key and the 7.0T will function normally as if in manual mode.
- When the stop key is pressed you will be prompted to confirm the deck will be returned to the lowest level.

# PROGRAMS SETUP

---

## Selecting and Customizing Programs

When a program is selected you have the option of modifying the settings. If you want to begin without entering new settings, just press the start key. This will bypass the programming of data and take you directly to the start of the program. If you want to change the settings, just follow the instructions in the message window. When you start a program the data from the set up menu will be used.

- During the manual program you will be able to scroll through the data in the message window by pressing the display key. You may also switch between the speed, incline or track displays by pressing the display key adjacent to the dot matrix display.
- When the program ends you may press start to begin the same program again or stop to exit the program, or you can save the program you just completed as the facility program by pressing the facility key and following the instructions in the message window.

## Manual

The manual program works as the name implies, manually. This means that you control the workload yourself, not the computer. To start the manual program follow the instructions below or just press the manual button then the enter button and follow the directions in the message window.

- Press the manual key then press the enter key.
- The message window will prompt you to enter the time for the program. You may enter the time using the up and down keys or the numeric key pad then press the enter key to accept.
- Now you are finished editing the settings and can begin the program by pressing the start key. All data calculations will use the patient information from the set up function (set up key at top left of console).

## PRESET PROGRAMS

---

The 7.0T has two preset exercise programs that have been designed for a variety of goals. The initial built-in level of difficulty for each program is set to a relatively easy level. You may adjust the level of difficulty (max speed) for each program before beginning.

The profiles shown in the dot matrix are merely pictures of the whole profile and will not change in size when the speed keys are pressed. When setting up a program you will enter the maximum speed setting for the peak of the profile. During the program the speed levels will change as the profile progresses. When the up key is pressed to request more speed the profile picture will not change, but the speed will increase. Pressing the speed keys actually change the peak level of the program not the current segment speed. You may need to change the peak setting several times by pressing the speed key before the current segment increases.

# PROGRAMS PRESET - CONTINUED

## PRESET PROGRAMS SPEED AND INCLINE SETTINGS

The preset program speed and incline levels are shown in the chart below. The Speed numbers shown in the chart indicate a percentage of the top speed of the program.

Prog	SEG	Warm Up			1	2	3	4	5	6	7	8	9	10	11	12	13	14	15	16	17	18	19	20	21	22	23	24	Cooldown		
Plateau	Speed	20	30	40	50	60	70	80	100	100	100	100	100	100	100	100	100	100	100	100	100	100	100	100	80	70	60	50	40	30	20
	Incline	0	0	0	0	0	0	0	0	0	0	0	0	0	0	0	0	0	0	0	0	0	0	0	0	0	0	0	0	0	0
Interval	Speed	20	30	40	50	60	60	70	80	100	60	60	70	80	100	60	70	100	60	70	100	60	70	80	70	60	60	50	40	30	20
	Incline	0	0	0	0	1	2	3	5	6	2	3	5	6	7	2	3	7	2	3	8	2	3	5	4	3	1	0	0	0	0

## PROGRAMMING PRESET PROGRAMS

- Select a program then press the enter key to begin customizing the program settings, or just press the start key to begin the program with the default settings. All data calculations will use the patient information from the set up function (set up key at top left of console).
- After selecting a program, press enter to set the program time. The Time window will blink with the default value of 30 minutes. You may use any of the up/down keys to adjust the time. After adjusting the time, press enter. (Note: You may press start at any time during the programming to begin with only settings you have modified at that point).
- The speed window will now be blinking, showing the preset top speed of the selected program. Use the up/down keys to adjust, and then press enter. Each program has various speed changes throughout; this allows you to limit the highest speed the program will attain during your workout.
- Now press the start key to begin your workout.
- There will be a 3 minute warm-up to begin. You can press the start button to bypass this and go straight to the workout. During the warm-up the clock will count down from 3 minutes.

## FACILITY PROGRAM

The facility program allows you to build and save a custom program. You can build your own custom program by following the instructions below or you can save any other preset program you complete as a custom program. The facility program allows you to further personalize it by adding your facility name.

## DESIGNING AND SAVING A NEW PROGRAM

---

- Press the facility key. The message window will show a welcome message; if you had previously saved a program, the message will contain the name you gave it. Then press the Enter key to begin programming.
- When you press enter, the message window will show “Name – A”, if there is no name saved. If the name “Custom Workout” had been previously saved, the message window will show “Name – Custom Workout” and the C in Custom will be blinking. If there is a name saved, you can change it or you may press the stop key to keep the name and continue to the next step. If you want to enter a name, use the up and/ or the down key to change the first letter then press enter to save the first letter and continue to the next letter. When you have finished entering the name, press the stop key to save the name and continue to the next step.
- The message window will ask you to enter an age. You may enter an Age, using the up and down keys or the numeric key pad, then press the enter key to accept the new number and proceed on to the next screen.
- You are now asked to enter a weight. You may adjust the weight number using the up and down keys or the numeric key pad then press enter to continue.
- Next is time. You may adjust the time and press enter to continue.
- Now you are asked to adjust the max level. This is the peak exertion level you will experience during the program. Adjust the level and then press enter.
- Now the first column will be blinking and you are asked to adjust the level for the first segment of the workout. When you finish adjusting the first segment, or if you don’t want to change, then press enter to continue to the next segment.
- The next segment will show the same level as the previously adjusted segment. Repeat the same process as the last segment then press enter. Continue this process until all twenty-four segments have been set.
- The message window will then tell you to press enter to save the program. After saving the program the message window says “New program saved” then will give you the option to start or modify the program. Pressing stop will exit to the start up screen.
- During the facility program you will be able to scroll through the data in the message window by pressing the adjacent Display key.

### RUNNING A SAVED PROGRAM

- Press user key then enter
- Enter time then press start to begin program.

# VO2 TEST

---

The Vo2 test is based on the Gerkin protocol, also known as the fireman's protocol, and is a sub-max Vo2 (volume of oxygen) test. The test will increase speed and elevation alternately until 85% of Max heart rate is attained. The time it takes the heart rate to reach 85% determines the test score (Vo2 max) as shown in the chart below.

Stage	Time	Speed	Grade	VO2 Max
1	0 to 1:00	4.5mph	0%	31.15
2.1	1:15	4.5mph	2%	32.55
2.2	1:30	4.5mph	2%	33.6
2.3	1:45	4.5mph	2%	34.65
2.4	2:00	4.5mph	2%	35.35
3.1	2:15	5.0mph	2%	37.45
3.2	2:30	5.0mph	2%	39.55
3.3	2:45	5.0mph	2%	41.3
3.4	3:00	5.0mph	2%	43.4
4.1	3:15	5.0mph	4%	44.1
4.2	3:30	5.0mph	4%	45.15
4.3	3:45	5.0mph	4%	46.2
4.4	4:00	5.0mph	4%	46.5
5.1	4:15	5.5mph	4%	48.6
5.2	4:30	5.5mph	4%	50
5.3	4:45	5.5mph	4%	51.4
5.4	5:00	5.5mph	4%	52.8
6.1	5:15	5.5mph	6%	53.9
6.2	5:30	5.5mph	6%	54.9
6.3	5:45	5.5mph	6%	56
6.4	6:00	5.5mph	6%	57

7.1	6:15	6.0mph	6%	57.7
7.2	6:30	6.0mph	6%	58.8
7.3	6:45	6.0mph	6%	60.2
7.4	7:00	6.0mph	6%	61.2
8.1	7:15	6.0mph	8%	62.3
8.2	7:30	6.0mph	8%	63.3
8.3	7:45	6.0mph	8%	64
8.4	8:00	6.0mph	8%	65
9.1	8:15	6.5mph	8%	66.5
9.2	8:30	6.5mph	8%	68.2
9.3	8:45	6.5mph	8%	69
9.4	9:00	6.5mph	8%	70.7
10.1	9:15	6.5mph	10%	72.1
10.2	9:30	6.5mph	10%	73.1
10.3	9:45	6.5mph	10%	73.8
10.4	10:00	6.5mph	10%	74.9
11.1	10:15	7.0mph	10%	76.3
11.2	10:30	7.0mph	10%	77.7
11.3	10:45	7.0mph	10%	79.1
11.4	11:00	7.0mph	10%	80

## VO2 - CONTINUED

---

### Before the test

- Make sure you are in good health; check with your physician before performing any exercise if you are over the age of 35 or persons with pre-existing health conditions.
- Make sure you have warmed up and stretched before taking the test.
- Do not take in caffeine before the test.

### Fitness test programming

- Press the Vo2 key and press enter.
- The message window will ask you to enter your age. You may adjust the age setting, shown in the Incline window, using the up and down keys then press the enter key to accept the new number and proceed on to the next screen.
- You are now asked to enter your Weight. You may adjust the weight setting, shown in the distance window, using the up and down keys then press enter to continue.
- Now press start to begin the test.

### During the test

- The console must be receiving a steady heart rate for the test to begin. You may wear a heart rate chest strap transmitter (Polar T31/T34).
- The test will start with a 3 minute warm-up at 3 mph (4.8 kph) before the actual test begins.
- The data shown during the test is:
  - Time indicates total elapsed time.
  - Incline in percent grade.
  - Distance in Miles or Kilometers depending on preset parameter.
  - Speed in mph or kph depending on preset parameter.
  - Target Heart Rate and Actual Heart Rate are shown in the message window.

### After the test

- Cool down for about one to three minutes.
- Take note of your score because the console will automatically return to the start-up mode after a few minutes.

# VO2 TEST - CONTINUED

---

## What the score means

VO2max Chart for males and very fit females

	18-25 years old	26-35 years old	36-45 years old	46-55 years old	56-65 years old	65+ years old
excellent	>60	>56	>51	>45	>41	>37
good	52-60	49-56	43-51	39-45	36-41	33-37
above average	47-51	43-48	39-42	35-38	32-35	29-32
average	42-46	40-42	35-38	32-35	30-31	26-28
below average	37-41	35-39	31-34	29-31	26-29	22-25
poor	30-36	30-34	26-30	25-28	22-25	20-21
very poor	<30	<30	<26	<25	<22	<20

VO2max Chart for females and de-conditioned males

	18-25 years old	26-35 years old	36-45 years old	46-55 years old	56-65 years old	65+ years old
excellent	56	52	45	40	37	32
good	47-56	45-52	38-45	34-40	32-37	28-32
above average	42-46	39-44	34-37	31-33	28-31	25-27
average	38-41	35-38	31-33	28-30	25-27	22-24
below average	33-37	31-34	27-30	25-27	22-24	19-22
poor	28-32	26-30	22-26	20-24	18-21	17-18
very poor	<28	<26	<22	<20	<18	<17

# SYMMETRY

---

The symmetry program provides basic gait information and a feedback graph. The program will measure the left and right step length and calculates the symmetry index. The message window will display the user's cadence, left and right step length in inches (or centimeters) and symmetry index.

The dot matrix display will show a graph indicating step symmetry so the user has a visual feedback to aid in improving their gait. If the user has a longer step length with their left leg the graph will increase in size on the left of the dot matrix as shown below.

When the program ends, either by the set time reaching zero or pressing stop twice at any time during the program, a summary is shown in the message window. The summary gives the average cadence, step lengths and average symmetry for the amount of time the user walked.

- Press the symmetry key then press the enter key.
- The message window will prompt you to enter the time for the program. You may enter the time using the up and down keys or the numeric key pad then press the enter key to accept and proceed to the next screen.
- Now you are finished editing the settings and can begin by pressing the Start key. All

data calculations will use the patient information from the set up function (set up key at top left of console).

- During the program you will be able to scroll through the data in the message window by pressing the display key.
- When the program ends you may press start to begin the same program again or stop to exit the program, or you can save the program you just completed as the facility program by pressing the facility key and following the instructions in the message window.

## BIOFEEDBACK MEASUREMENTS AND GRAPH

Below is a sample picture showing the symmetry graph. In the message window there is an average step cadence, left and right step length and symmetry measurements. In the example below the step length numbers shown indicate that the left leg is stepping longer than the right leg, 26 vs. 15 inches. The graph reflects the longer stride of the left leg. If the step length was even, only two dots would be lit on the bottom center of the graphic screen.

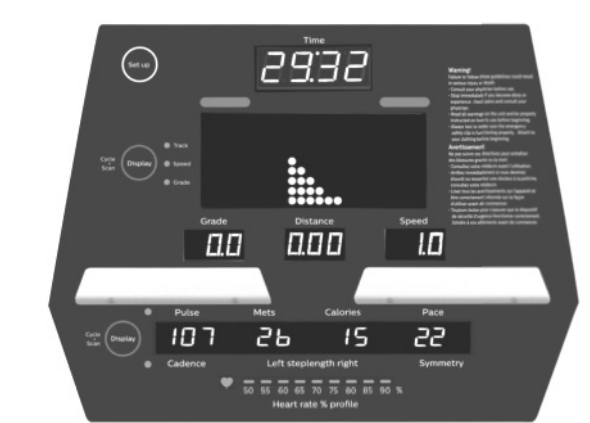

Note: For some types of gaits it may be possible that the left/right data can be displayed in reverse. If this occurs, press the symmetry program key to flip the display.

## DATA TRANSFER SOFTWARE INSTRUCTIONS

---

- Works with newer 7.0T, 7.0T, 7.0T, 7.0T and 7.0T consoles with USB ports on the back
- The software works with Windows 10, 7 and XP series, with .Net Framework 2.0.
- The output for the data is in a .CSV file format.
- <http://www.dyaco.com/software>
- Please follow the website instructions to download software.
- Use a USB cable (type a to type b, illustrated to the right) to connect the product and the computer.

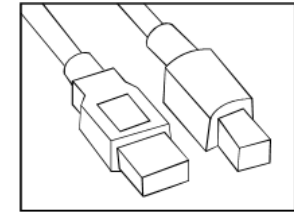

### Step 1.

Download the software from the link (<http://www.dyaco.com/software>) and connect the console of the product to the computer via USB cable. Click "Install" when you see the pop-up window as below during installation.

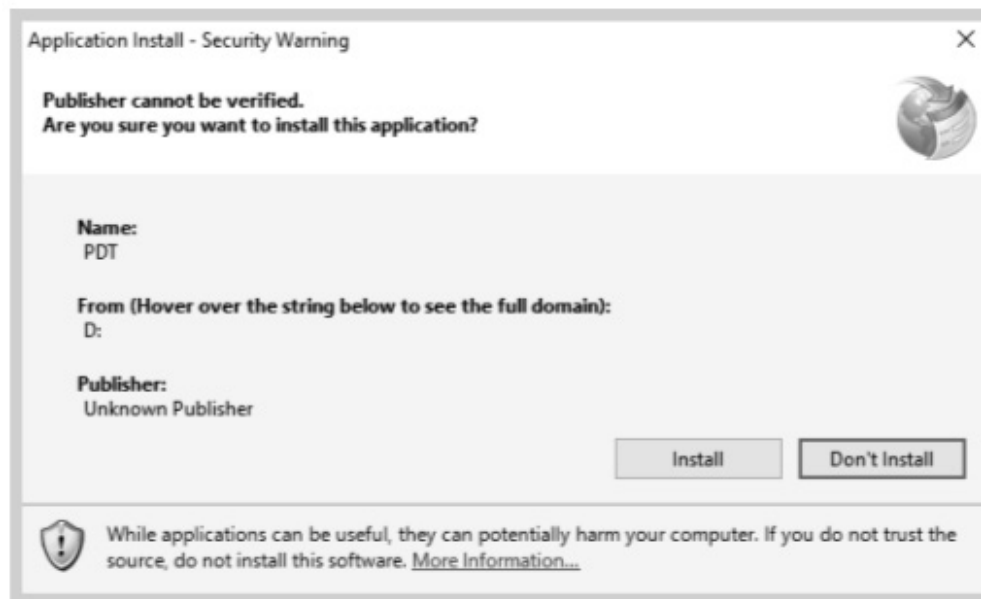

## DATA TRANSFER SOFTWARE INSTRUCTIONS - CONTINUED

---

Step 2.

Click “Connect” or “Change” to select the connecting port (left figure). After clicking the “Change”, or connecting to the wrong port, the COM port selection window pops up (right figure). Select the correct COM port and click “Connect”.

Selecting COM port

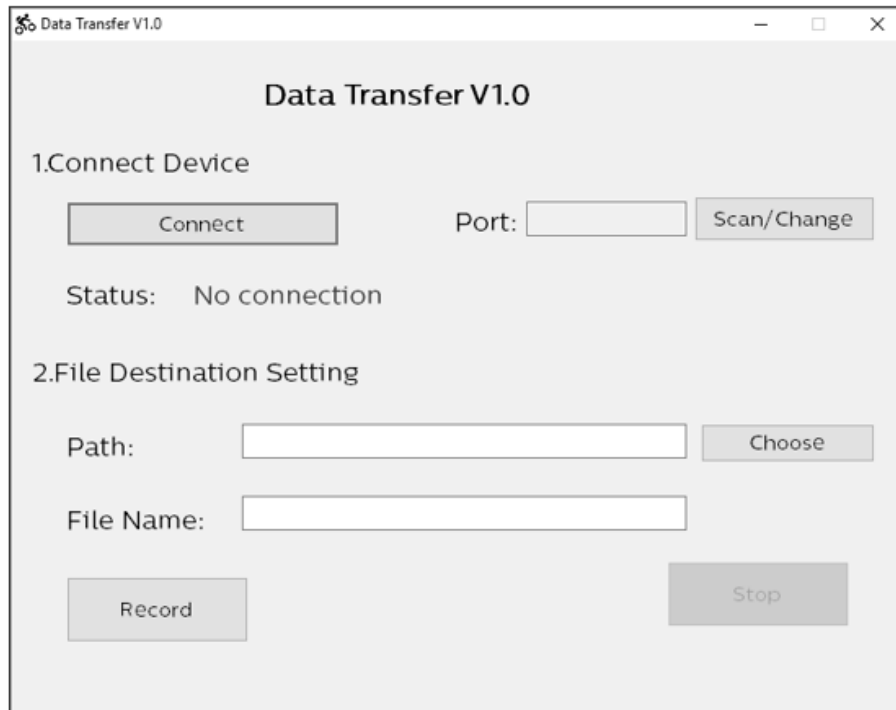

Pop-Up COM Port Selection Window

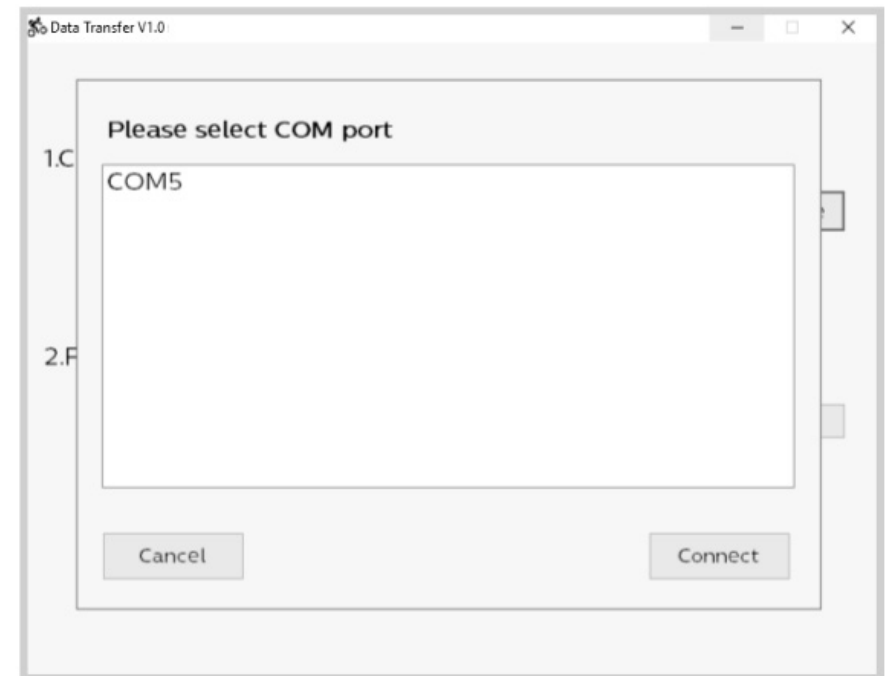

# DATA TRANSFER SOFTWARE INSTRUCTIONS - CONTINUED

Step 3.

After the status shows “Connected” and the product model name to the right, choose the file path and create the file name for saving the data. Click the “Record” button to start collecting data. Click “Stop” or quit the program from the console of the product to stop the data collection process. The saved data can be found at the assigned destination.

Click record button

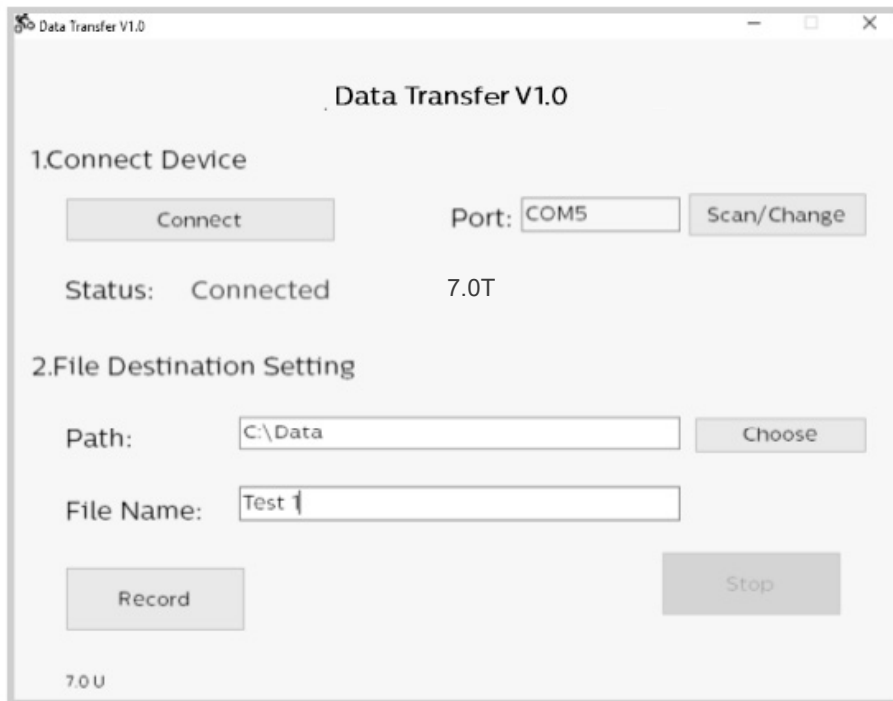

Recording complete

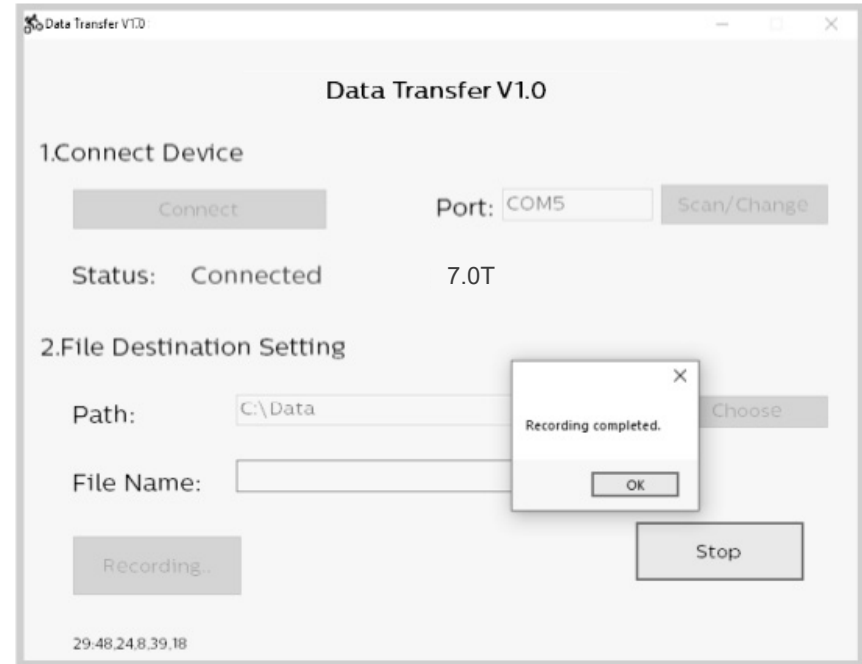

The file is saved in .CSV format, which can be opened by Microsoft Excel. Example shown below.

Model:	7.0T	Date & Time:	2017/8/1 10:02	Program:	MANUAL				
Program time	SPM	Steps	Level	Watt	Left Watt	Right Watt	Symmetry	L/R	
00:01	0	0	1	0	0	0	0	0 R	
00:02	0	0	1	0	0	0	0	0 R	
00:03	0	0	1	4	0	4	200	R	
00:04	0	0	1	4	0	4	200	R	
00:05	29	1	1	8	8	4	66	L	
00:06	48	2	1	14	8	0	11	D	

## USING A HEART RATE TRANSMITTER

---

Note: The chest strap transmitter is not a standard part, but is a separate purchase. Most transmitters that operate at 5kHz frequency will also work.

How to wear your wireless chest strap transmitter?

- Attach the transmitter to the elastic strap using the locking parts.
- Adjust the strap as tightly as possible as long as the strap is not too tight to remain comfortable.
- Position the transmitter with the logo centered in the middle of your body facing away from your chest (some people must position the transmitter slightly left of center). Attach the final end of the elastic strap by inserting the round end and, using the locking parts, secure the transmitter and strap around your chest.
- Position the transmitter immediately below the pectoral muscles.
- Sweat is the best conductor to measure very minute heart beat electrical signals. However, plain water can also be used to pre-wet the electrodes (2 black square areas on the reverse side of the belt and either side of transmitter). It's also recommended that you wear the transmitter strap a few minutes before your work out. Some users, because of body chemistry, have a more difficult time in achieving a strong, steady signal at the beginning. After "warming up", this problem lessens. As noted, wearing clothing over the transmitter/strap doesn't affect performance.
- Your workout must be within range - distance between transmitter/ receiver – to achieve a strong steady signal. The length of range may vary somewhat but generally stay close enough to the console to maintain good, strong, reliable readings. Wearing the transmitter immediately against bare skin assures

you of proper operation. If you wish, you may wear the transmitter over a shirt. To do so, moisten the areas of the shirt that the electrodes will rest upon.

- Note: The transmitter is automatically activated when it detects activity from the user's heart. Additionally, it automatically deactivates when it does not receive any activity. Although the transmitter is water resistant, moisture can have the effect of creating false signals, so you should take precautions to completely dry the transmitter after use to prolong battery life (estimated transmitter battery life is 2500 hours). If your chest strap has a replaceable battery the replacement battery is CR2032.

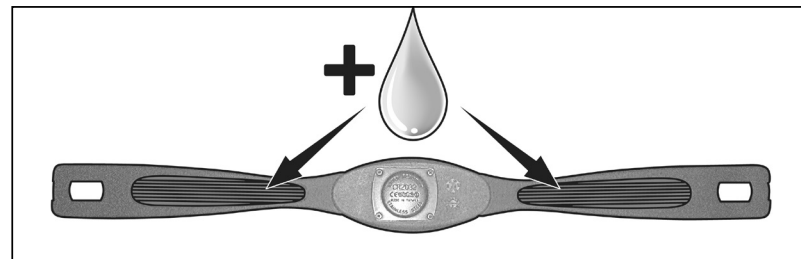
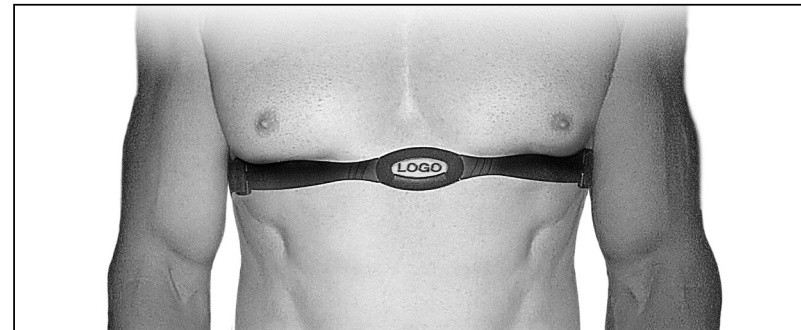

## **CHEST STRAP WARNING\* (NOT INCLUDED)**

---

### **Erratic Operation**

 Caution! Do not use this 7.0T for Heart Rate Control unless a steady, solid Actual Heart Rate value is being displayed. High, wild, random numbers being displayed indicate a problem..

Areas to look for interference which may cause erratic heart rate:

1. Treadmills is not properly grounded.
2. Microwave ovens, TV's, small appliances, etc.
3. Fluorescent lights.
4. Some household security systems.
5. Perimeter fence for a pet.
6. Some people have problems with the transmitter picking up a signal from their skin. If you have problems try wearing the transmitter upside down. Normally the transmitter will be oriented so the Spirit Fitness logo is right side up.
7. The antenna that picks up your heart rate is very sensitive. If there is an outside noise source, turning the whole machine 90 degrees may de-tune the interference.
8. Another Individual wearing a transmitter within 3' of your machine's console.

If you continue to experience problems contact your dealer.

## HEART RATE PROGRAM OPERATION

---

To start the HR program follow the instructions below or just press the HR key then the Enter button and follow the directions in the message window.

- Press the HR key then press the Enter key.
  - The message window will ask you to enter your Age. You may enter your Age, using the Up and Down keys or the numeric key pad, then press the Enter key to accept the new number and proceed on to the next screen.
  - You are now asked to enter your Weight. You may adjust the Weight number using the Up and Down keys or the numeric key pad, then press enter to continue.
  - Next is Time. You may adjust the Time and press enter to continue.
  - Now you are asked to adjust the Heart rate Level. This is the heart rate level you will experience during the program. Adjust the level and then press enter.
  - Now you are finished editing the settings and can begin your workout by pressing the Start key. You can also go back and modify your settings by pressing the Enter key. NOTE: At any time during the editing of data you can press the Stop key to go back one level, or screen.
  - If you want to increase or decrease the workload at any time during the program press the Up or Down key. This will allow you to change your target heart rate at any time during the program.
  - During the HR program you will be able to scroll through the data in the message window by pressing the adjacent Display key.
- When the program ends you may press Start to begin the same program again or Stop to exit the program or you can save the program you just completed as a custom user program by pressing the Facility key and following the instructions in the message window.

## MACHINE CARE

---

### Post-Workout Machine Care

Wipe down all areas in the sweat path with a damp cloth after each workout. If a squeak, thump, clicking or rough feeling develops the main cause is most likely one of two reasons:

1. The hardware was not sufficiently tightened during assembly. All bolts that were installed during assembly need to be tightened as much as possible. It may be necessary to use a larger wrench than the one provided if you cannot tighten the bolts sufficiently. It is important to note that 90% of calls to the service department for noise issues can be traced to loose hardware.
2. The crank arm nut needs to be retightened. If squeaks or other noises persist, check that the unit is properly leveled. There are 2 leveling pads on the bottom of the rear stabilizer, use a 14mm wrench (or adjustable wrench) to adjust the levelers.

### Post-Workout Machine Care

1. Store your machine according to the instructions when not in use.
2. Use a slightly damp cloth to clean areas where sweat or oil made contact with the machine.
3. Use a microfiber cloth to clean the screen and remove unwanted oils and other things that may damage the screen.
4. Avoid leaving paper or other small debris in the cupholders.

### Sanitizing Your Spirit Fitness Equipment

- Unupholstered high-contact surfaces (hard plastics) can be sanitized using a 75% isopropyl alcohol solution and a clean, dry cloth. Spray surfaces to be sanitized, and use the dry cloth to wipe clean. Allow surfaces to dry before using.
- For upholstered or soft-plastic surfaces, use a conditioner after sanitizing. Be sure to follow the instructions provided by the conditioner manufacturer to ensure proper use of the conditioner.
- Alternatively, you can make your own spray by mixing the proper ratio of isopropyl alcohol and distilled water to reach a 75% solution.
- For more details on sanitization, or to learn how to make your own spray solution, please visit:  
[support.spiritfitness.com/hc/en-us/articles/4406787148564](https://support.spiritfitness.com/hc/en-us/articles/4406787148564)

# MACHINE CARE

---

## Belt and deck

Your 7.0T uses a very high-efficient low-friction deck and belt. Performance is maximized when the bed is kept as clean as possible. Use a soft, damp cloth or paper towel to wipe the edge of the belt and the area between the belt edge and frame. Also reach as far as practical directly under the belt edge. This should be done once a month to extend belt and deck life. Use water only - no cleaners or abrasives. A mild soap and water solution along with a nylon scrub brush will clean the top of the textured belt. Allow the belt to dry before using.

## General cleaning

Dirt, dust, and carpet fibers can block air inlets and accumulate on the running belt. On a monthly basis: vacuum underneath your 7.0T to prevent buildup. Once a year, you should remove the motor hood and vacuum out dirt that may accumulate. Unplug power cord before this task.

## Belt adjustments

Tread-belt tension adjustment

Adjustment must be made from the rear roller. The adjustment bolts are located at the end of the step rails in the end caps, as noted in diagram below.

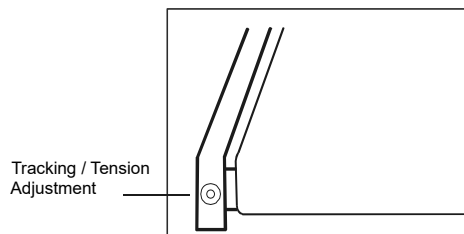

Note: Adjustment is through small hole in the end cap.

Tighten the rear roller bolts only enough to prevent slippage at the front roller. Turn both tread-belt tension adjustment bolts with a 10mm allen wrench in increments of 1/4 to 1/2 turn each and inspect for proper tension by walking on the belt at a low speed, making sure the belt does not slip. Keep tensioning the bolts until the belt stops slipping.

If you feel the belt is tight enough, but it still slips, the problem may be a loose Motor drive belt under the front motor cover.

Do not overtighten- Over tightening will cause belt damage and premature bearing failure.

## Treadbelt tracking adjustment

The performance of your 7.0T is dependent on the frame running on a reasonably level surface. If the frame is not level, the front and back roller cannot run parallel, and constant belt adjustment may be necessary.

The 7.0T is designed to keep the tread-belt reasonably centered while in use. It is normal for some belts to drift near one side while the belt is running with no one on it. After a few minutes of use, the tread-belt should have a tendency to center itself. If, during use, the belt continues to move toward one side, adjustments are necessary.

## To set treadbelt tracking

Use a 10mm Allen wrench to adjust the rear roller. Make tracking adjustments from the left side only. Set belt speed at approximately 2 to 3 mph.

Remember, a small adjustment can make a dramatic difference!

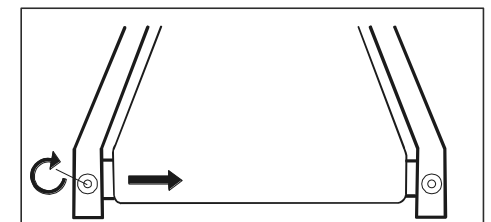

## **MACHINE CARE - CONTINUED**

---

Turn the bolt clockwise to move the belt to the right. Turn the bolt only a 1/4 turn and wait a few minutes for the belt to adjust itself. Continue to make 1/4 rotation turns until the belt stabilizes in the center of the running deck.

The belt may require periodic tracking adjustment depending on use and walking/running characteristics. Some users will affect tracking differently. Expect to make adjustments as required to center the tread-belt. Adjustments will become less of a maintenance concern as the belt is used. Proper belt tracking is an owner responsibility common with all rehabilitation treadmills.

### **Attention**

Damage to the running belt resulting from improper tracking /tension adjustments is not covered under the warranty.

### **Maintenance menu in console software**

The console has built in maintenance/diagnostic software. The software will allow you to change the console settings from English to Metric and turn off the beeping of the speaker when a key is pressed for example. To enter the Maintenance menu (may be called Engineering mode, depending on version) press and hold down the Start, Stop and Enter keys. Keep holding the keys down for about 5 seconds and the message window will display "Maintenance menu". Press the enter button to access the menu below:

## MACHINE CARE - CONTINUED

---

### Maintenance Mode

Press and hold the start, stop and enter key at the same time, until the display shows “Maintenance menu” press the enter key. You can now scroll through the menu using the up and down keys. Use the stop key to return to previous menu selection. The menu selections are:

#### Key Test

- Press each key to verify it is functioning correctly

#### Display test

- Lights all LED lights

#### Functions

- Sleep  
Turns sleep mode on or off. When off, display power is always on.
- Pause  
Turns pause mode on or off. When on, pause lasts 30 minutes.
- Odometer reset  
Reset odometer readings
- Units  
Set display to English or metric readings
- Grade Return (GS Mode)  
Turns GS mode on or off. Returns the elevation to the lowest setting when pause is pressed
- Beep  
Turns the speaker (beep sound) on or off.
- Service Mode

### Incline

- MW scrolls: “Use incline keys for front use speed keys for rear” then switch to VR display below.
- Incline keys operate front motor, speed keys operate rear motor. Hold down up/down key to operate motor, stop when key is released. Motor is allowed to move until limit switch activated.
- MW displays A/D values for both position sensors. Example of the readings F 920 R 70. F=Front incline sensor and R = Rear incline sensor. The readings will be opposite: when at lowest incline the front will show a large number and rear will be small.

### Drive Motor

- MW displays: “Use speed keys to move motor”. Each key press increases motor speed 0.1 mph/kph
- MW then shows: RPM 000 AMP 00.0. The sensor reading indicates motor RPM, not belt speed. The AMP is measuring motor current

### Motor Brake

- Brake ON (brake coil turned off) (User press enter to turn Brake OFF)

### Step Sensors

#### Test

- Use sensor outputs to light DM similar to Symmetry display. This test is only to make sure the sensors are functioning and does not test accuracy. The DM graph shows left and right sensor activity when stepping on the deck. Both sides of the graph will light at the same time, but the side the user steps with would show more segments lit.

## **MACHINE CARE - CONTINUED**

---

### Calibration

- MW: START LEFT SIDE
- When Start is pressed the MW shows: AD \_\_\_ TGT 65
- Speaker will beep slowly when magnet distance is too far, quickly when near and steady when correct.
- Press enter to continue
- MW: START RIGHT SIDE
- When Start is pressed the MW shows: AD \_\_\_ TGT 65
- Speaker will beep slowly when magnet distance is too far, quickly when near and steady when correct.
- User press enter or stop to end calibration

### Acceleration Key Lock

- MW show "ACCEL KEY", press enter then MW shows "ACCEL LOCKED". This is the default. If the user presses the up or down key the MW shows "ACCEL UNLOCKED". Press enter to exit.

### Speed limit setting

- MW shows "SPEED LIMIT", press enter. The MW shows Limit 10.0 MPH. This is the default setting and is the top forward speed of the 7.0T.
- If the user presses the down key the MW shows Limit 9.9 MPH. The top limit can be changed in 0.1 MPH increments.
- The minimum speed limit setting is 3.0 mph.

### Security

- MW show "SECURITY" MW shows "CHILD LOCK ON" or OFF , Sets the Child Lock function. This function locks out the keypad until a pre-determined key sequence is pressed. Key sequence = Start & Enter held down together until unlocked.

## **MACHINE CARE - CONTINUED**

---

### Factory and Acceleration Settings

- Enter the Factory settings; press Start and Speed Fast keys while console is in power up reset. User presses enter
- UNITS: ENGLISH

The default setting is English. User can press any up/down arrows to change to Metric. User presses enter.

- ADJUST MIN SPEED THEN PRESS ENTER

Default value is 0.1 mph and can be adjusted up to 0.5mph.

The speed number to be shown in the speed window.

- ADJUST MAX SPEED THEN PRESS ENTER

Default value is 10.0 mph and can be adjusted down to 3.0 mph.

The speed number to be shown in the speed window

- ADJUST REVERSE SPEED MAX THEN PRESS ENTER

Default value is 3.0 mph and can be adjusted down to 1.0 mph and up to 5.0 mph.

- ADJUST BELT SPEED ACCELERATION TIME PER EACH 1.0 MPH

The default is 0:03 seconds and will be shown in the Time window.

The time can be adjusted down to 0:01 and up to 1:00 minute

- ADJUST BELT SPEED DECELERATION TIME PER EACH 1.0 MPH

The default is 0:03 seconds and will be shown in the Time window.

The time can be adjusted down to 0:01 and up to 1:00 minute

- Press Enter for Grade Calibration Or To Exit Hold Stop Key Until Reset.

- Adjust Max Incline Then Press Enter

The default value is 15 and can be adjusted down to 10

- Adjust Max Decline Then Press Start to calibrate

The default value is 5 and can be adjusted up to 10

- If Grade calibration is successful the MW shows "Passed" for 3 seconds then exit to idle mode.

## ERROR MESSAGE & TROUBLESHOOTING

---

Error Codes

### **E1 Over Current**

Deck Lube  
Bad Drive or Motor  
Check Brake

### **E2 Over Volt**

Check AC line V

### **E3 Over V Decel**

Check AC line V  
Check Brake

### **E4 Ground Fault**

Check wiring  
Replace Drive

### **E5 IGBT Fault**

Check wiring  
Replace Drive

### **E6 Drive Ovrload**

Deck Lube  
Brake locked  
Bad Drive  
Bad Motor

### **E7 Thrm Ovrload**

Brake locked  
Deck Lube  
Bad Drive  
Bad Motor

### **E8 Over Torque**

Brake locked  
Deck Lube  
Bad Drive  
Bad Motor

### **E9 Over I Speed**

Check Brake  
Deck Lube  
Bad Drive  
Bad Motor

### **E10 Over I Accel**

Deck Lube  
Bad Drive  
Bad Motor

### **E11 Over I Decel**

Deck Lube  
Bad Drive  
Bad Motor

### **E12 EPROM RD**

Check AC Line V  
Reset Power  
Bad Drive

### **E13 EPROM WR**

Check AC Line V  
Reset Power  
Bad Drive

### **E14 Ext Fault**

Reset Power

### **E15 U Phase I**

Reset Power  
Bad Drive

### **E16 W Phase I**

Reset Power  
Bad Drive

### **E17 HW Fault**

Reset Power  
Bad Drive

### **E18 IGBT O-Heat**

Bad Drive Fan  
Dirty Heat Sink

### **E19 Ambient Temp**

Air Vent Blocked  
Bad Fan

### **E20 Inrush Fault**

Reset Power  
Bad Drive

### **E21 In Sig Lost**

Check Wiring  
Bad Drive

### **E22 RS-485 Flt**

Check Wiring

### **E23 PID Error**

Check Wiring  
Chk Para Setting

### **E24 PU Comm**

Bad Drive

### **E25 Auto Tune**

Chk Motor wires  
Reset Power

### **E26 Bk Chopper**

Reset Power  
Bad Drive

### **E27 PG Error**

Check Motor

### **E28 Phase Loss**

Check Wiring  
Bad Drive

### **E29 I Signl Stop**

Reset Power

Bad Drive

### **E30 CPU Error**

Electronic circuit fault

### **E31 Fan**

Drive Fan Bad

### **E32 Analog In**

Check Wiring  
Bad Drive

### **E33 Over Trque**

Mechanical  
Deck Lube  
Brake

Bad Motor

Bad Drive

### **E34 Thrm Ovrld 2**

Brake locked  
Deck Lube

Bad Drive

Bad Motor

### **E35 Motor Sel**

Motor Wiring

### **E36 LV Bus Run**

Check AC Line V  
Bad Drive

### **E37LV Bus**

Check AC Line V  
Bad Drive

### **E38 Ext BB**

Para Settings

### **ERR Incline Err**

(Shows in Grade window)

### **ER2 Decline Err**

(Shows in Grade window)

# SPECIFICATIONS

---

**REF** 7.0T

## Manufacturer

 Dyaco International Inc.  
No. 1, Gong 1st Rd., Hemei  
Township, Changhua  
County 50843, Taiwan

## Dimensions

Length : 94.8"

Width : 48.7"

Height : 57.5"

## Product Weight

496 Lbs.

## Speed

Forward: 0.0 to 10.0 mph (0.0 to 16 kph)

Reverse: 0.0 to 3.0 mph (0.0 to 5 kph)

## Incline

Front: 0 to 15% Grade

Rear: 0 to 10% Grade

## Disposal

Reference should be made to local regulations concerning the disposal of this product at the end of useful life.

## Readouts

Time, Grade, Distance, Speed, Pulse, METs, Calories, Pace, Cadence, Left and Right Step Length, Symmetry Index

## Patient weight capacity

440 Lbs. (200 Kgs.)

## Power

120 volts, 60 Hz, dedicated 20-amp circuit (NEMA 5-20P power plug /receptacle type )

## CERTIFICATIONS

CAN/CSA -C22.2 No. 60601-1:14 , ANS/AAMI ES60601-1:2005+A2 (R2012) +A1,  
IEC 60601-1-2:2014, EN 60601-1-2:2015,  
IEC 60601-1:2005+A1:2012, EN 60601-1:2006+A1:2013+A12:2014  
EN ISO 20957:2013, ISO 14971; 2019

# SPECIFICATIONS - CONTINUED

Guidance and manufacturer's declaration – electromagnetic compatibility			
The 7.0T is intended for use in the electromagnetic environment specified below. The customer or the user of the 7.0T should assure that it is used in such an environment.			
Emissions test	Compliance	Electromagnetic environment – guidance	
RF emissions CISPR 11	Group 1	The 7.0T uses RF energy only for its internal function. Therefore, its RF emissions are very low and are not likely to cause any interference in nearby electronic equipment.	
RF emissions CISPR 11	Class B	The 7.0T is suitable for use in all establishments, including domestic establishments	
Immunity test	IEC 60601 test level	Compliance level	Electromagnetic environment – guidance
Electrostatic discharge (ESD) IEC 61000-4-2	□6 kV contact □8 kV air	□6 kV contact □8 kV air	Floors should be wood, concrete or ceramic tile. If floors are covered with synthetic material, the relative humidity should be at least 30 %.
Power frequency (50/60 Hz) magnetic field IEC 61000-4-8	3 A/m	3 A/m	Power frequency magnetic fields should be at levels characteristic of a typical location in a typical commercial or hospital environment.
Radiated RF IEC 61000-4-3	3 V/m 80 MHz to 2,5 GHz	3 V/m	$d = 1,2 \sqrt{P}$ 80 MHz to 800 MHz $d = 2,3 \sqrt{P}$ 800 MHz to 2,5 GHz Where P is the maximum output power rating of the transmitter in watts (W) according to the transmitter manufacturer and d is the recommended separation distance in meters (m). Field strengths from fixed RF transmitters, as determined by an electromagnetic site survey, a) should be less than the compliance level in each frequency range. B) Interference may occur in the vicinity of equipment marked with the following symbol: 

Recommended separation distances between portable and mobile RF communications equipment and the 7.0T			
The 7.0T is intended for use in an electromagnetic environment in which radiated RF disturbances are controlled. The customer or the user of the 7.0T can help prevent electromagnetic interference by maintaining a minimum distance between portable and mobile RF communications equipment (transmitters) and the 7.0T as recommended below, according to the maximum output power of the communications equipment.			
Rated maximum output power of transmitter W	Separation distance according to frequency of transmitter m		
	150 kHz to 80 MHz $d = 1,2 \sqrt{P}$	80 MHz to 800 MHz $d = 1,2 \sqrt{P}$	800 MHz to 2,5 GHz $d = 2,3 \sqrt{P}$
0,01	0,12	0,12	0,23
0,1	0,38	0,38	0,73
1	1,2	1,2	2,3
10	3,8	3,8	7,3
100	12	12	23
For transmitters rated at a maximum output power not listed above, the recommended separation distance d in meters (m) can be estimated using the equation applicable to the frequency of the transmitter, where P is the maximum output power rating of the transmitter in watts (W) according to the transmitter manufacturer. NOTE 1 At 80 MHz and 800 MHz, the separation distance for the higher frequency range applies. NOTE 2 These guidelines may not apply in all situations. Electromagnetic propagation is affected by absorption and reflection from structures, objects and people.			

Immunity test	IEC 60601 test level	Compliance level	Electromagnetic environment – guidance
Electrical fast transient/burst IEC 61000-4-4	+/-2 kV for power supply lines +/-1 kV for input/output lines	+/-2 kV for power supply lines +/-1 kV for input/output lines	Mains power quality should be that of a typical commercial or hospital environment.

- Note
- If the device is interfered by power or signal cable, image quality may be reduced or abnormally displayed. Such kind of interference images could be easily identified and differentiated from the physiological characteristics of patient and longer clinical time consumed but wouldn't have any diagnostic accuracy issue.
- If there is a certain frequency of image interference, there is a need of isolation or filtering of the RF signal.

# EXPLODED VIEW DIAGRAM

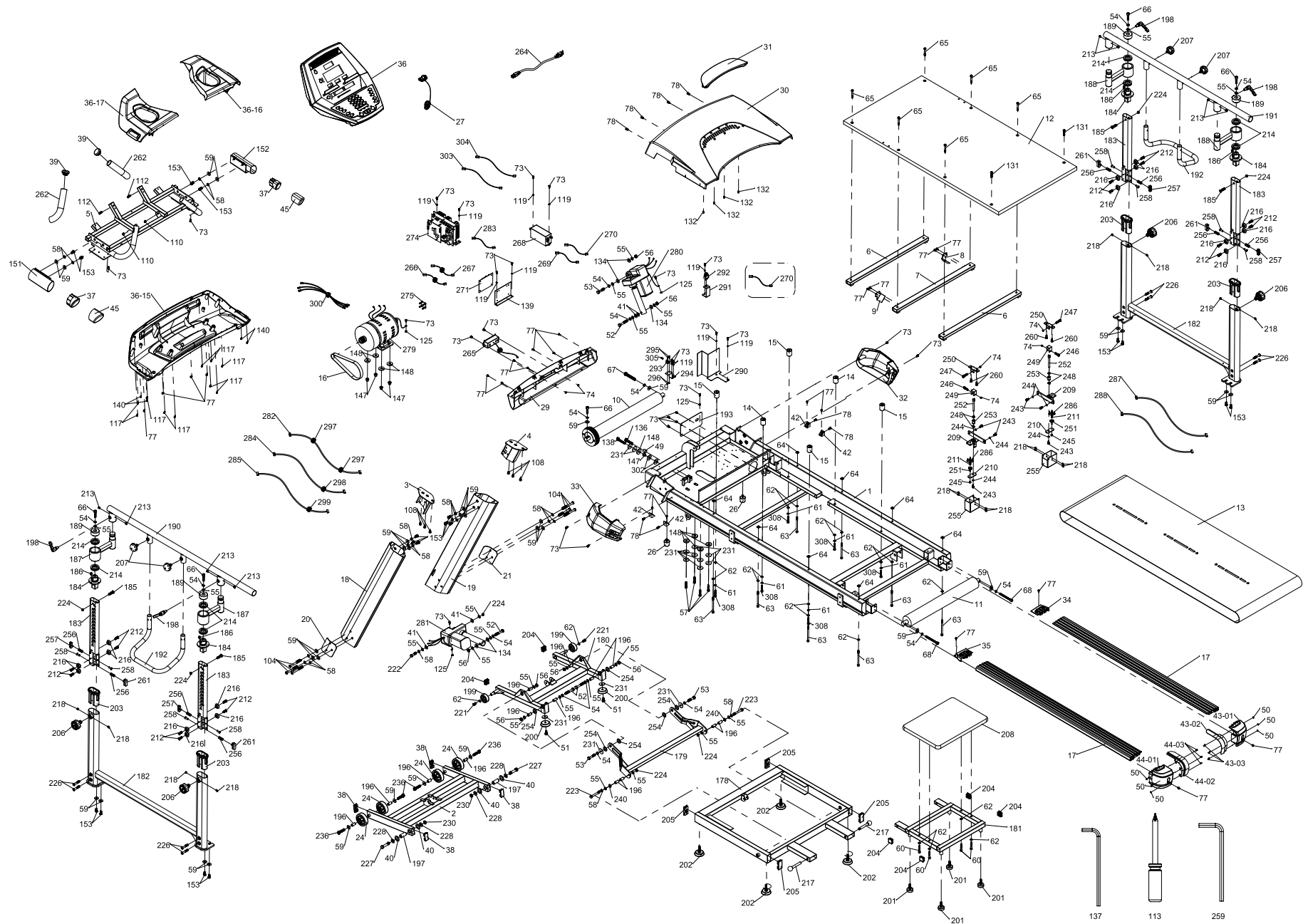

# PARTS LIST

1	Main Frame	1
2	Incline Bracket	1
3	Console Mast Locking Assembly ( L )	1
4	Console Mast Locking Assembly ( R )	1
5	Console Support	1
6	Running Deck Stabilizer Assembly(A)	2
7	Running Deck Stabilizer Assembly(B)	1
8	Belt Guide(R)	1
9	Belt Guide(L)	1
10	Front Roller W/Pulley	1
11	Rear Roller	1
12	Running Deck	1
13	Running Belt	1
14	Cushion A	2
15	Cushion B	4
16	Drive Motor Belt, Poly-V	1
17	1380m/m Aluminum Foot Rail	2
18	Aluminum Upright (L)	1
19	Aluminum Upright (R)	1
20	Upright Fixing Plate(L)	1
21	Upright Fixing Plate(R)	1
24	Ø82 x Ø14 x 35m/m Transportation Wheel	4
26	Incline Rubber Foot	2
27	800m/m Safety Key	1
29	Front Motor Cover	1
30	Motor Top Cover	1
31	Top Motor Cover Plate	1
32	Motor Base Cap (R)	1
33	Motor Base Cap (L)	1
34	Foot Rail Cap (R)	1
35	Foot Rail Cap (L)	1
36	Console Assembly	1
36~15	Console Bottom Cover	1
36~16	Console Top Cover(R)	1
36~17	Console Top Cover(L)	1
37	Oval Eye Tube Endcap	2

38	Square End Cap	4
39	Handpulse End Cap	2
40	Stable Wheel Spacer	4
41	Ø10 x Ø25 x 0.8T Nylon Washer	4
42	Motor Cover Anchor(D)	4
43	Rear Adjustment Base (R)	1
44	Rear Adjustment Base (L)	1
45	76 x 52 x 80m/m Handgrip Foam	2
49	Insulation bushing	1
51	3/8" x UNC16 x 3/4" Hex Head Bolt	2
52	M10 x P1.5 x 65L Hex Head Bolt	4
53	M10 x P1.5 x 50L Hex Head Bolt	3
54	Ø10 x 1.5T Spring Washer	15
55	3/8" x Ø19 x 1.5T Flat Washer	22
56	M10 x P1.5 x 8T Nyloc Nut	7
57	3/8" x UNC16 x 1-1/2" Socket Head Cap Bolt	4
58	Ø10 x 2T Spring Washer	19
59	Ø10 x Ø25 x 2T Flat Washer	32
60	M8 x P1.25 x 45L Socket Head Cap Bolt	4
61	Ø8 x 1.5T Spring Washer	6
62	Ø8 x Ø16 x 1T Flat Washer	20
63	M8 x P1.25 x 110L Socket Head Cap Bolt	8
64	M8 x P1.25 x 6.5T Square Nut	8
65	M8 x P1.25 x 55L Flat Head Countersink Bolt	6
66	M10 x P1.5 x 40L Socket Head Cap Bolt	5
67	M10 x P1.5 x 80L Socket Head Cap Bolt	1
68	M10 x P1.5 x 100L Socket Head Cap Bolt	2
73	M5 x P0.8 x 12L Phillips Head Screw	29
74	M5 x P0.8 x 5T Nyloc Nut	6
77	M5 x 12L Tapping Screw	23
78	Ø5 x 15L Sheet Metal Screw	8
104	3/8" x UNC16 x 3-3/4" Button Head Socket Bolt	6
108	M8 x P1.25 x 12L Socket Head Cap Bolt	6
110	M5 x P0.8 x 10L Phillips Head Screw	2
112	M5 x P0.8 x 30L Phillips Head Screw	2

# PARTS LIST

113	Phillips Head Screw Driver	1
117	Ø3.5 x 12L Sheet Metal Screw	10
119	Ø5 x 1.5T Spring Washer	13
125	Ø5 x 0.6T Star Washer	4
131	M8 x P1.25 x 35L Flat Head Countersink Bolt	2
132	Ø3 x 8L Tapping Screw	4
134	Ø10 x Ø24 x 3T Nylon Washer	5
136	3/8" x UNC16 x 2" Socket Head Cap Bolt	1
137	L Allen Wrench	1
138	3/8" x UNC16 x 2-1/4" Socket Head Cap Bolt	1
139	Controller L-Plate	1
140	M3 x 10L Sheet Metal Screw	4
147	Ø10 x Ø14 x 14L Isolation Bushing	5
148	Ø13 x Ø35 x 5T Nylon Washer	9
151	Left Handgrip	1
152	Right Handgrip	1
153	3/8" x UNC16 x 3/4" Button Head Socket Bolt	18
178	Frame Base	1
179	Folding Assembly Bracket	1
180	Incline Bracket	1
181	Step Up Frame	1
182	Parallel Bar Frame	2
183	P. Bar Vertical Adjustment Tube	4
184	P. Bar Bearing Inner Race	4
185	3/8" x 1-1/2" Button Head Socket Bolt	4
186	M5 x P0.8 x 6L Socket Head Cap Bolt	4
187	P. Bar Horizontal Adjustment Arm (L)	2
188	P. Bar Horizontal Adjustment Arm (R)	2
189	P.Bar Horizontal Adj. Cap	4
190	Handle Bar(L)	1
191	Handle Bar(R)	1
192	P.Bar Lift Assist Handle	2
193	Fan Back Plate	1
196	Ø14 x 10 x 25L Powder metallurgy Sleeve	14
197	Ø20 x 13.4 x 41L Powder metallurgy Sleeve	2
198	Seat/Handlebar Adj. Locking Lever	4

199	Ø54 x 25mm/m Transportation Wheel	2
200	Rubber Foot	2
201	Ø37mm x 3/8" Adjustment Foot Pad	4
202	Ø55 x 3/8" Adjustment Foot Pad	4
203	Slider Sleeve	4
204	30 x 30 Square End Cap	6
205	30 x 60 x 2T Square End Cap	4
206	Locking Knob	4
207	Brake Tension Knob	4
208	Step Up Platform	1
209	Sensor Mounting Plate	2
210	Magnet Plate	2
211	Braking Magnet	2
212	M8 x P1.25 x 25L Flat Head Countersink Bolt	16
213	M5 x P0.8 x 12L Flat Head Socket Screw	8
214	P. Bar Bearing	8
216	PJ Wheel	16
217	Step Up Frame Pop Pin	2
218	M4 x P0.7 x 8L Phillips Head Screw	16
221	5/16" x UNC18 x 5/8" Hex Head Bolt	2
222	3/8" x UNC16 x 1-1/2" Hex Head Bolt	1
223	3/8" x UNC16 x 3" Hex Head Bolt	2
224	3/8" x UNC16 x 7T Nyloc Nut	7
226	3/8" x UNC16 x 2" Button Head Socket Bolt	8
227	1/2" x UNC12 x 2-1/4" Hex Head Bolt	2
228	Ø13 x Ø26 x 2T Flat Washer	4
230	1/2" x UNC12 x 8T Nyloc Nut	2
231	3/8" x Ø35 x 2T Flat Washer	14
236	3/8" x UNC16 x 1-3/4" Socket Head Cap Bolt	4
240	Ø14 x Ø20 x 2T Flat Washer	2
243	M5 x P0.8 x 15L Socket Head Cap Bolt	6
244	Ø5 x Ø12 x 1T Flat Washer	6
245	M6 x P1.0 x 5T Lock Nut	2
246	M5 x P0.8 x 30L Socket Head Cap Bolt	2
247	M5 x P0.8 x 35L Socket Head Cap Bolt	2
248	Ø15 C Ring	4

## PARTS LIST

249	U-joint, Step Sensor	2
250	U-joint Mounting Plate	2
251	Ø20 x M6 x 20L Step Magnet Holde	2
252	Plunger, Step Sensor	2
253	Linear Bushing	2
254	Rotate Axle Spacer	6
255	Cover, Step Sensor Assembly	2
256	Ø13.5 x 30m/m Spring	8
257	Brake Pad, P. Bar Slide	4
258	M6 x Ø8 x 19L Nut	8
259	L Wrench	1
260	M6 x P1.0 x 20L Button Head Socket Bolt	4
261	Brake Pad - Wool Felt	4
262	EVA Foam for Rail Strap	2
264	Power Cord	1
265	AC Electronic Module	1
266	200m/m Connecting Wire (White)	1
267	200m/m Connecting Wire (Black)	1
268	Filter	1
269	150m/m Connecting Wire (White)	1
270	150m/m Connecting Wire (Black)	2
271	Lower Control Board	1
274	Inverter	1
275	Encoder	1
279	AC Motor	1
280	400m/m Incline Motor	1
281	1550m/m Incline Motor	1
282	2100m/m Computer Cable	1
283	800m/m Computer Cable	1
284	2100m/m Computer Cable	1
285	Communication Cable	1
286	Step Sensor Board	2
287	800m/m Step Sensor Cable, Right	1
288	1550m/m Step Sensor Cable, Left	1
290	Back Plate	1
291	Plate	1

292	Breaker	1
293	Grounding Brush	1
294	Brush Holder	1
295	M3 x 10L Phillips Head Screw	2
296	M3 x 2.5T Lock Nut	2
297	Ferrite Core(29m/m)	2
298	Ferrite Core(21.4m/m)	1
299	Ferrite Core(30m/m)	1
300	80m/m Connecting Cable Of Motor	1
302	Ø16 x Ø35 x 1T Flat Washer	2
303	300m/m Connecting Wire (White)	1
304	300m/m Connecting Wire (Black)	1
305	Ø5.2 x 0.4T x 14.5L Constrict Spring	1
308	M8 x 40L Socket Head Cap Bolt	6

# **WARRANTY - COMMERCIAL**

---

Effective October 23, 2024- 7.0T Treadmill LIMITED WARRANTY

Spirit Fitness warrants all its Treadmill parts for a period of time listed below from the date of retail sale, as determined by sale receipt, or in the absence of a sales receipt eighteen (18) months from the original factory shipping date. Spirit Fitness' responsibilities include providing new or remanufactured parts, at Spirit Fitness' option, and technical support to our independent dealers and servicing organizations. In the absence of a dealer or service organization, these warranties will be administered by Spirit Fitness directly to a consumer. The warranty period applies to the following components:

## **Commercial Warranty**

\*Prisons and correctional facilities are excluded from warranty coverage

<b>Warranty</b>	<b>Parts</b>	<b>Labor</b>
Commercial	5 Years	1 Year

## **RESPONSIBILITIES OF THE FACILITY**

1. The facility is responsible for the items listed below:
2. The warranty registration card must be completed and returned to the address listed on the card within 10 days of the original purchase, or completed online to validate the manufacturer's limited warranty.
3. Proper use of the fitness equipment in accordance with the instructions provided in this manual
4. Proper installation in accordance with instructions provided with the fitness equipment and with all local electric codes.
5. Proper connection to a grounded power supply of sufficient voltage, replacement of blown fuses, repair of loose connections or defects in house or facility wiring.
6. Expenses for making the fitness equipment accessible for servicing, including any item that was not part of the fitness equipment at the time it was shipped from the factory.
7. Damages to the fitness equipment finish during shipping, installation or following installation.
8. Routine maintenance of this unit as specified in this manual.

## **WARRANTY - CONTINUED**

---

What is not covered?

### **EXCLUSIONS**

This warranty does not cover the following:

1. CONSEQUENTIAL, COLLATERAL, OR INCIDENTAL DAMAGES SUCH AS PROPERTY DAMAGE AND INCIDENTAL EXPENSES RESULTING FROM ANY BREACH OF THIS WRITTEN OR ANY IMPLIED WARRANTY.  
Note: Some states do not allow the exclusion or limitation of incidental or consequential damages, so this limitation or exclusion may not apply to you.
2. Service call reimbursement to the consumer. Service call reimbursement to the dealer that does not involve malfunction or defects in workmanship or material, for units that are beyond the warranty period, for units that are beyond the service call reimbursement period, for Treadmill not requiring component replacement, or Treadmill not in ordinary household or light commercial use.
3. Damages caused by services performed by persons other than authorized Spirit Fitness service companies; use of parts other than original Spirit Fitness parts; or external causes such as corrosion, discoloration of paint or plastic, alterations, modifications, abuse, misuse, accident, improper maintenance, inadequate power supply, or acts of God.
4. Products with original serial numbers that have been removed or altered.
5. Products that have been: sold, transferred, bartered, or given to a third party.
6. Spirit Fitness reserves the right to request proof of purchase if no warranty record exists for the product.
7. THIS WARRANTY IS EXPRESSLY IN LIEU OF ALL OTHER WARRANTIES EXPRESSED OR IMPLIED, INCLUDING THE WARRANTIES OF MERCHANTABILITY AND/OR FITNESS FOR A PARTICULAR PURPOSE.
8. Product used in prisons and correctional facilities.
9. Warranties outside of the United States may vary. Please contact your local dealer for details.

Product features or specifications as described or illustrated are subject to change without notice. All warranties are made by Spirit Fitness, Inc. This warranty applies only in the 48 contiguous United States. NOTE: This does not include Alaska or Hawaii.

## **WARRANTY - CONTINUED**

---

Responsibilities of the Owner

### **SERVICE**

Keep your bill of sale. Twelve (12) months from the date on the bill of sale or eighteen (18) months from the date of factory shipping as determined by the serial number establishes the labor warranty period should service be required. If service is performed, it is in your best interest to obtain and keep all receipts. This written warranty gives you specific legal rights. You may also have other rights that vary from state to state. Service under this warranty must be obtained by following these steps, in order:

1. Contact your selling authorized Spirit Fitness dealer. OR
2. Contact your local authorized Spirit Fitness service organization.
3. If there is a question as to where to obtain service, contact our service department at (870) 935-1107.
4. Spirit Fitness' obligation under this warranty is limited to repairing or replacing, at Spirit Fitness' option, the product through one of our authorized service centers. All repairs must be preauthorized by Spirit Fitness. If the product is shipped to a service center freight charges to and from the service center will be the customer's responsibility. For replacement parts shipped while the product is under warranty, the customer will be responsible for shipping and handling charges.
5. The owner is responsible for adequate packaging upon return to Spirit Fitness. Spirit Fitness is not responsible for damages in shipping. Make all freight damage claims with the appropriate freight carrier. **DO NOT SHIP ANY UNIT TO OUR FACTORY WITHOUT A RETURN AUTHORIZATION NUMBER.** All units arriving without a return authorization number will be refused.

For any further information, or to contact our service department by mail, send your correspondence to:

Spirit Fitness, Inc.

P.O. Box 2037

Jonesboro, AR 72402-2037

Product features or specifications as described or illustrated are subject to change without notice. All warranties are made by Spirit Fitness, Inc. This warranty applies only in the 48 contiguous United States. NOTE: This does not apply to Alaska or Hawaii.





3000 Nestle Road Jonesboro, AR 72401 | Phone: 800-258-8511 | Fax: 870-935-7611

[www.spiritfitness.com](http://www.spiritfitness.com)

©2024 All Rights Reserved. 7.0T Owner's Manual